

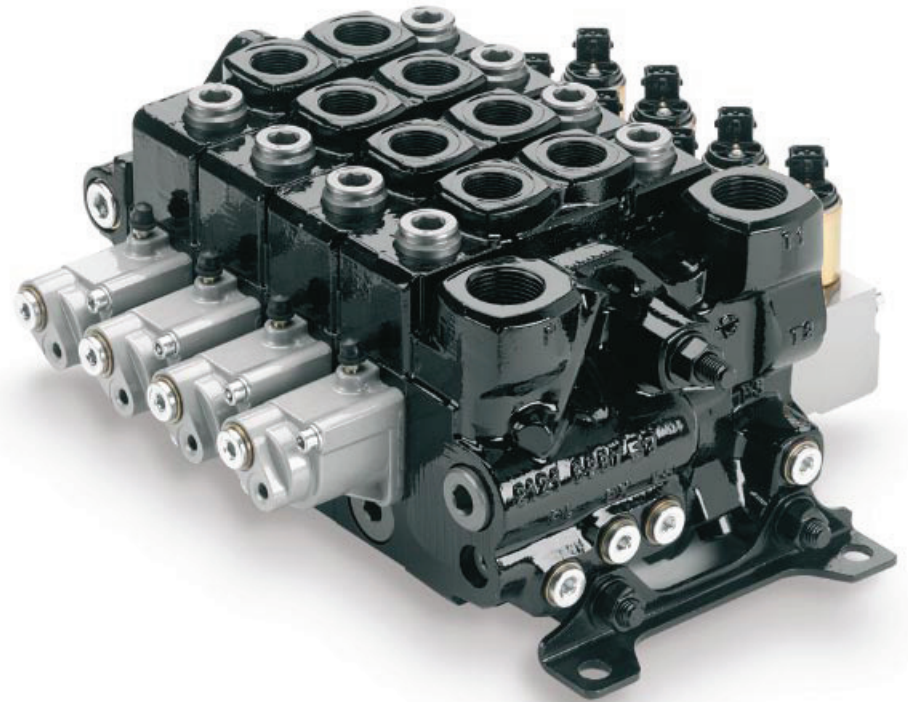

aerospace
climate control
electromechanical
filtration
fluid & gas handling
hydraulics
pneumatics
process control
sealing & shielding



K170LS

Mobile Directional Control Valve

Proportional, Load Sensing, Pre-compensated



ENGINEERING YOUR SUCCESS.

Catalogue layout

This catalogue has been designed to give a brief overview of K170LS valves, and to make it easy for you to study and choose from the different options available, so that we may customize your valve in accordance with your wishes. In addition to general information and basic technical data, the catalogue therefore contains descriptions of the options available for various so-called "function areas" of the valve.

Each function area is given as a subheading, followed by a brief description. When options are available for a function area, the subheading is followed by an "Item number" in brackets, e.g. **Pressure relief valve [16]**. This is followed by a series of coded

options, e.g. **PA1, Y1**, together with a brief description of what each code represents. Alternatively, one or more pressure, flow or voltage options are given.

On page 8 is a general circuit diagram showing the basic function areas in a K170LS valve and the item numbers that represent them. Naturally, the same item numbers are used for the respective function areas in all sub-circuit diagrams that appear elsewhere in the catalogue. Please note that, unless stated otherwise, all sections and views of the valves have been drawn as seen from the inlet section.

How to order your valve

The K170LS directional control valve can be easily specified using Parker computer programme. This means the customer can optimise his valve specification to give the best performance for his application and specific hydraulic system.

Once the demands placed on each individual function have been specified the computer will select the valve design required to give optimum performance. The computer also produces complete documentation for your valve, in the form of a detailed specification and hydraulic circuit diagram.

The computer also generates a unique identification number for each valve type and customer. The number is then stamped into the I.D. plate of each valve. The specification of your valve is then recorded by Parker, so that exact identification of the product can be made at any time in the future to facilitate repeat ordering or servicing.

Early consultation with Parker saves time and money

Our experienced engineers have in-depth knowledge of the different types of hydraulic system and the ways in which they work. They are at your disposal to offer qualified advice on the best system for the desired combination of functions, control

characteristics and economic demands. By consulting Parker early in the project planning stage, you are assured of a comprehensive hydraulic system that gives your machine the best possible operating and control characteristics.

Conversion factors

1 kg	= 2.2046 lb
1 N	= 0.22481 lbf
1 bar	= 14.504 psi
1 l	= 0.21997 UK gallon
1 l	= 0.26417 US gallon
1 cm ³	= 0.061024 in ³
1 m	= 3.2808 feet
1 mm	= 0.03937 in
9/5 °C + 32	= °F

WARNING

FAILURE OR IMPROPER SELECTION OR IMPROPER USE OF THE PRODUCTS AND/OR SYSTEMS DESCRIBED HEREIN OR RELATED ITEMS CAN CAUSE DEATH, PERSONAL INJURY AND PROPERTY DAMAGE.

This document and other information from Parker Hannifin Corporation, its subsidiaries and authorized distributors provide product and/or system options for further investigation by users having technical expertise. It is important that you analyze all aspects of your application, including consequences of any failure, and review the information concerning the product or system in the current product catalogue. Due to the variety of operating conditions and applications for these products or systems, the user, through its own analysis and testing, is solely responsible for making the final selection of the products and systems and assuring that all performance, safety and warning requirements of the application are met.

The products described herein, including without limitation, product features, specifications, designs, availability and pricing, are subject to change by Parker Hannifin Corporation and its subsidiaries at any time without notice.

Offer of Sale

Please contact your Parker representation for a detailed "Offer of Sale".

Table of contents	Page
General Information	4
Technical Data	6-7
Hydraulic circuit diagram	8
Inlet Section	9
Internal pilot pressure supply [12]	9
Pilot pressure [13]	9
Pilot filter [14].....	9
Load signal system.....	10
Inlet section type [15]	10
Pressure relief valve [16].....	10
Pressure setting [17]	11
Tank connection T2 [24]	11
Counter pressure valve	11
Tank connection T1 [25]	11
Pump connection P1 [26]	11
End Section	12
End section [30].....	12
LS-connection [31]	12
Pump connection P2 [32]	12
Tank connection T3 [34]	12
Separate tank connection for the pilot circuit [40].....	12
Spool Section	13
Spool section with actuator type PC.....	13
Spool actuators [50]	14
PC, PCH - Hydraulic spool actuator	14
Electro-hydraulic proportional spool actuator	15
Connector types [56]	15
Pilot restrictor [55 A,B].....	16
Spool options.....	17
Spool function [60].....	17
Flow requirement [61 A,B].....	17
Area relationship [62]	18
Load characteristics [63]	18
Force feedback [64 A,B]	18
Pressure compensator and/or load-hold check valve [66].....	19
Pressure compensators	19
Damping of pressure compensator [67]	20
Spool designation [69].....	20
Flow settings [72]	20
Feed reduction valves [75].....	20
Setting of feed reduction in the A-port [75A]	20
Setting of feed reduction in the B-port [75B]	20
Port relief and/or anti-cavitation valves [76 A,B]	21
Separate anti-cavitation valve in service ports	21
Anti cavitation characteristics	21
Function block [90-99]	22
Connectors	22
Dimensional drawing	23

[00] refers to item numbers in the customer specification.

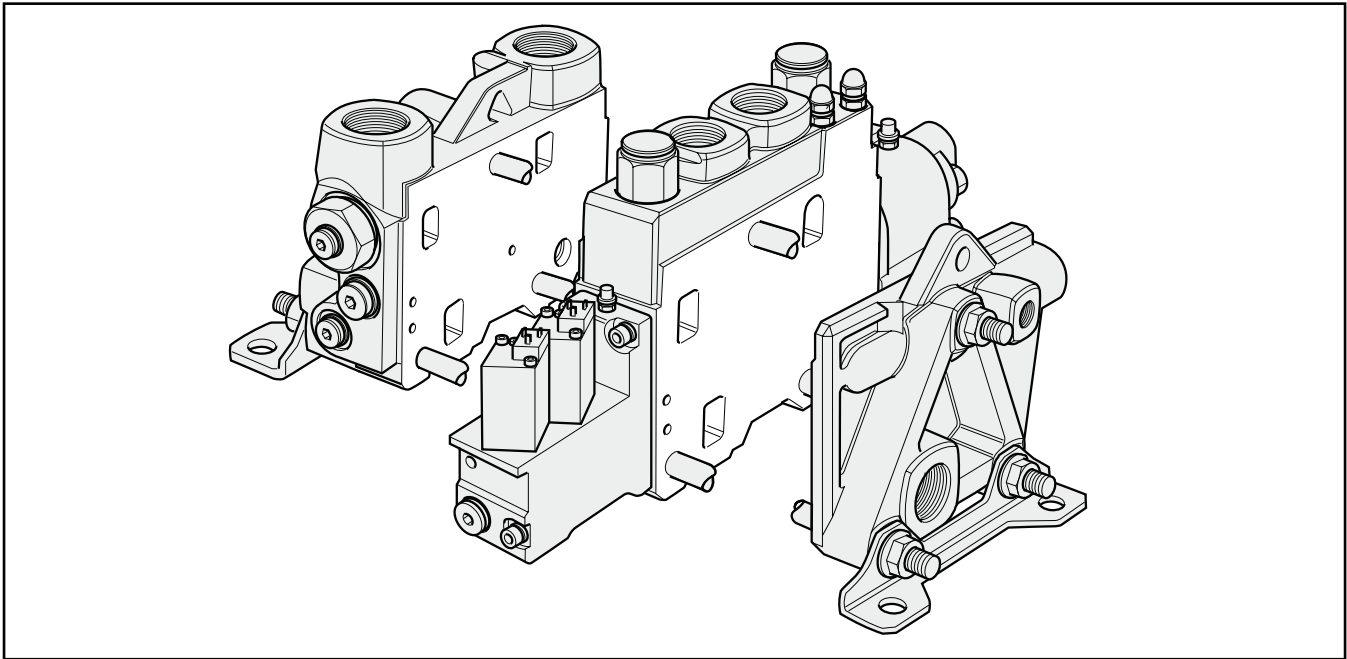

The K170LS is a stackable, proportional, load-sensing (LS), pressure-compensated directional control valve, which can also be adapted to give force-sensing control characteristics. It is designed for many different applications, both mobile and industrial, and is widely used in machines such as front-end loaders, backhoe loaders, excavators, cranes, forestry equipment, metal presses and forging hammers.

With its function-adapted spool sections, wide range of additional functions and standard accessories, the K170LS enables the user to optimise the machine and its hydraulic system in the following ways:

Compact system construction

While the K170LS can contain many integrated functions, it requires a minimum of external piping. With the aid of a special combo-inlet, it can be mounted directly to the similar, smaller-flow L90LS directional valve, giving great compactness and outstanding operating economy.

Freedom in machine design

The K170LS is designed for proportional hydraulic or electro-hydraulic remote control. This gives great freedom in the location of components, and in the running of pipework, hoses and cables.

Economy

The K170LS can be modified or expanded to suit customer specifications. Function and application adaptation enables energy consumption to be kept to a minimum.

Control characteristics

The control characteristics for both lifting and lowering movements are outstanding, thanks to the unique function adaptation of spools, pressure compensators, feed reducing valves etc. Each function is completely independent of other simultaneously operated functions.

Construction

The K170LS is a stackable valve, and can be delivered in combinations of 1 to 9 spool sections. It is designed for system pressures of up to 330 bar, and can be fitted with motor-port relief valves that open at a maximum pressure of 350 bar. Suitable flow range can be up to 280 l/min (2x280 l/min with mid inlet). The recommended flow per section is 170 l/min with a pressure compensator, and 220 l/min without.

As an optional, the K170LS can be given a built-in pilot pressure supply in the inlet section, as well as pressure compensation and feed reduction in the spool sections. The feed reducer is adjustable from 30 to 330 bar. Force feed-back (optional) enables a force-sensing function to be incorporated in to the valve. Moreover, fixed or pilot-operated counter pressure valves can be integrated into inlet section to give back-pressure supported load lowering and exceptionally good anti-cavitation characteristics.

System adaptation

The K170LS is a load sensing, pressure-compensated directional valve with unique possibilities for adaptation in respect of both functions and applications to systems with variable LS pumps.

Valve characteristics

- Copied load signal - The system permits consumption in the load signal line to the pump, without the signal level being affected.
- Pressure compensation - Pressure-compensated spools for lifting and lowering movements. Separate compensator for each spool section for excellent pressure compensation.
- Feed reducers - Individually adjustable for each service port. Reduction can also be controlled remotely.
- Force control - Force-sensing control characteristics (made available through the pressure-feedback option) give not only effective force control, but also more gentle transition across at speed changes and greater stability in the hydraulic system.
- Counter pressure valve - Built-in counter pressure valve in two versions (fixed setting or pilot control) for best application-adaptation.
- Flexible, modular construction makes it easy to re-build or expand the valve to meet changing needs.
- Our port-relief valves have outstanding pressure characteristics, even as secondary pressure limiters, and respond very quickly to sudden changes in load.
- The valve can be flanged to specially adapted Parker function blocks that enable even more functions to be integrated into a compact, single unit with minimal piping.

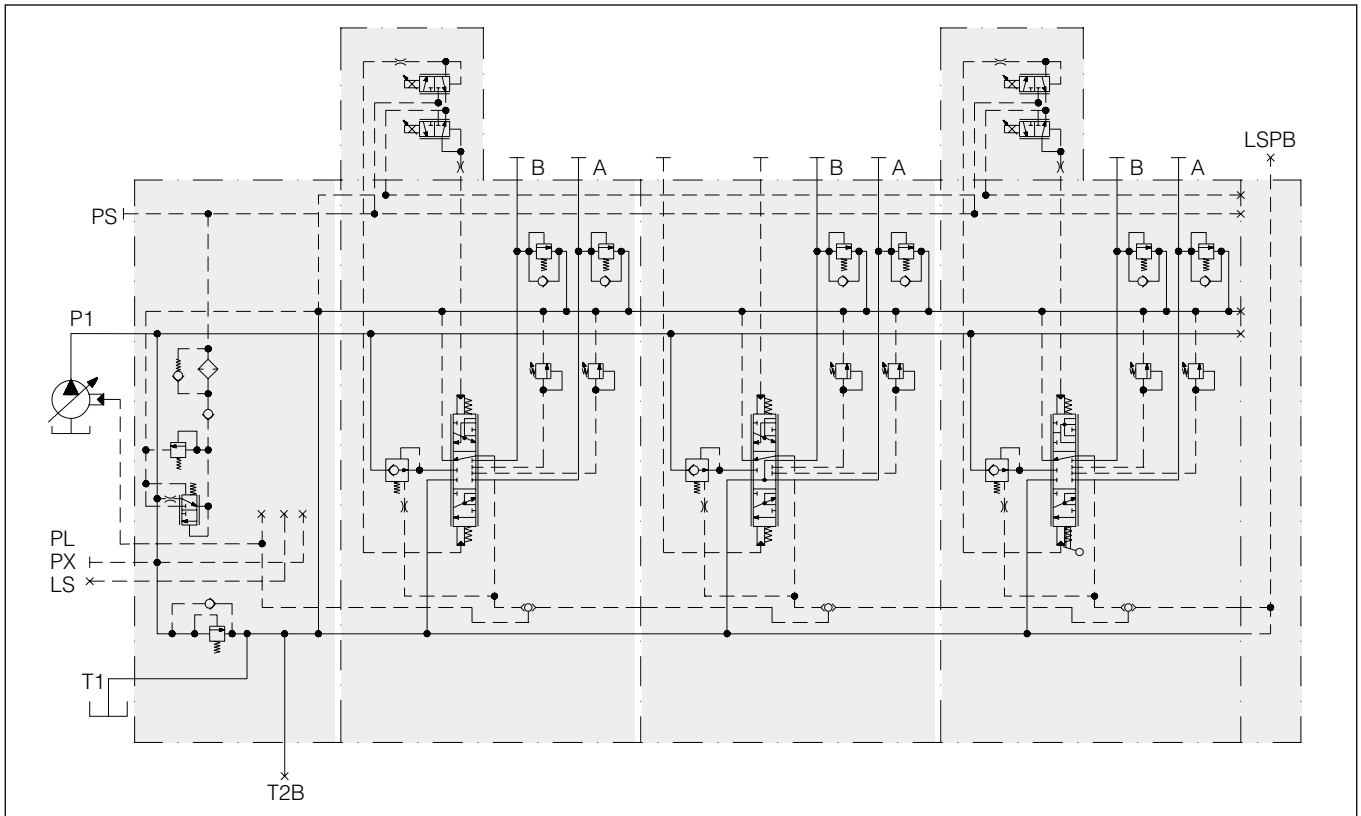

K170LS with built-in hydraulic, electro-hydraulic, or combined manual and electro-hydraulic spool actuator. In this example, the valve is not equipped with a copying function for the load signal (LS).

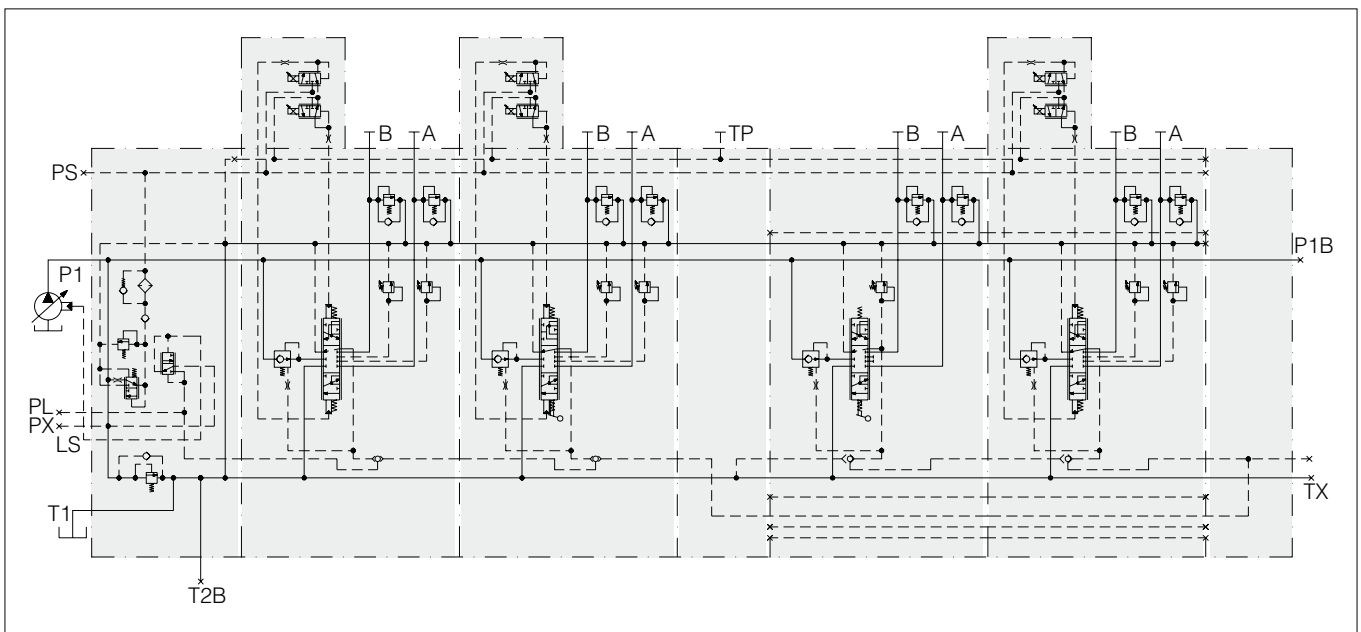

The K170LS valve connected to a L90LS valve. The L90LS valve is used for functions which requires less flow. This gives price advantages as well as operational advantages. The valve in this example fitted with an internal pilot pressure supply and individual pressure compensator, feed reduction and pressure relief valves.

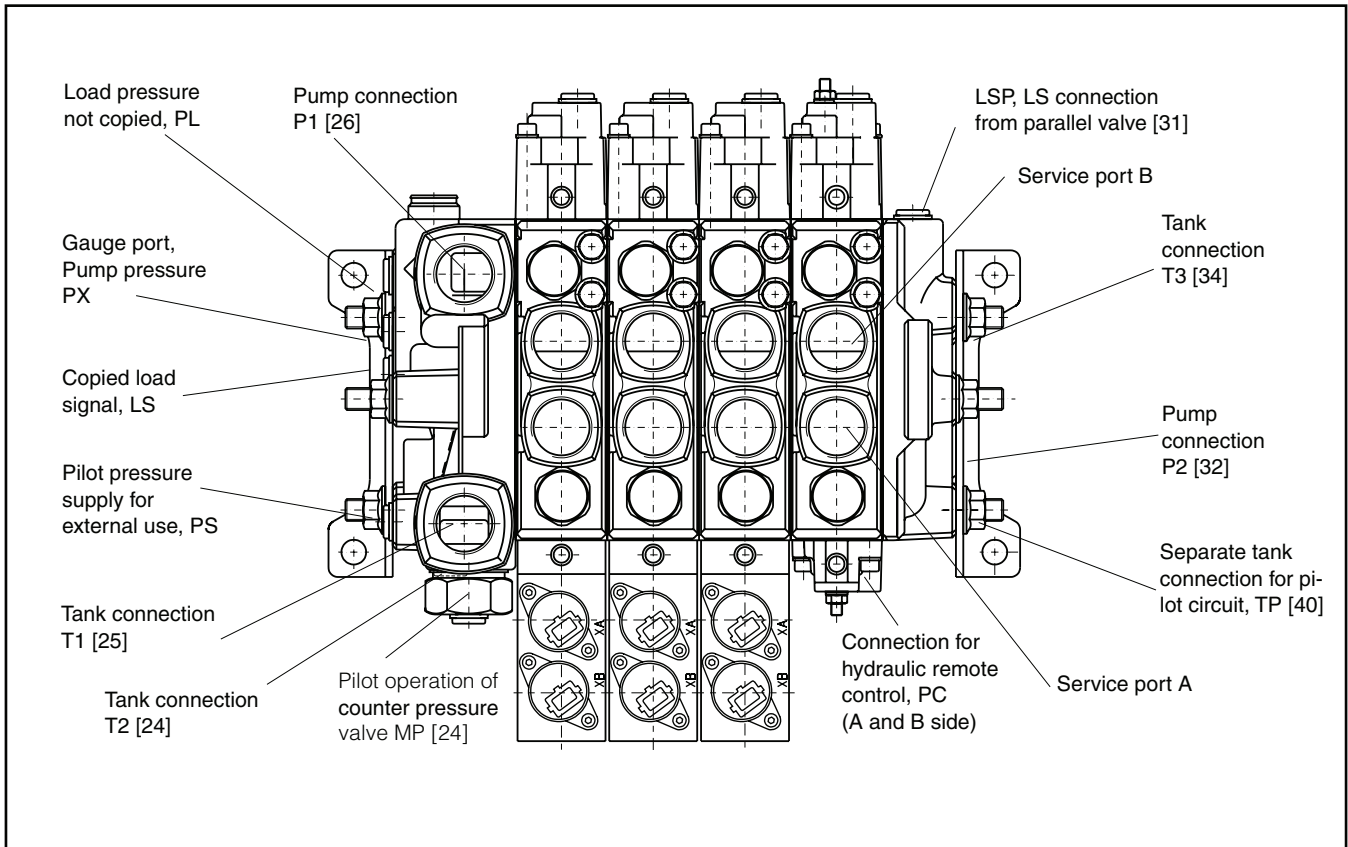

Pressure

Pump inlet	max 330 ¹⁾ bar (4800 ¹⁾ psi)
Service ports	max 350 ¹⁾ bar (5000 ¹⁾ psi)
Pump regulator	Δp min 18 ²⁾ bar (260 ²⁾ psi)
Compensator K3	Δp min 30 ²⁾ bar (435 ²⁾ psi)
Return line pressure, static	max 15 bar (220 psi)
1) Pressures given are maximum absolute relief pressures	
2) Pressure drop pump to valve max 3 bar (44 psi)	

Internal pilot pressure

Standard setting	35 bar (500 psi)
Optional setting	45 bar (650 psi)

Feed reducer

Adjustment range	30 to 330 bar (435 to 4800 psi)
------------------	------------------------------------

Counter pressure valve

Fixed setting	5 bar (70 psi)
Pilot operated, signal pressure	max 30 bar (435 psi)
Pressure ratio, pilot signal : counter pressure	1.2 : 1

Recommended flow rates

Pump connection	max 280 ³⁾ l/min (75 USgpm)
Service port with compensator	max 170 ⁴⁾ l/min (45 USgpm)
Service port without compensator	max 220 ⁴⁾ l/min (60 USgpm)
Return from service port	max 280 l/min (75 USgpm)
3) 2 x 280 l/min (2 x 75 USgpm) with mid inlet section	
4) Depending on spool version	

Temperature

Oil temperature, working range +20 to 90 °C (68 to 194 °F)*

* Product operating limits are broadly within the above range, but satisfactory operation within the specification may not be accomplished. Leakage and response will be affected when used at temperature extremes and it is up to the user to determine acceptability at these levels.

Filtration

Filtration must be arranged so that Target Contamination Class 20/18/14 according to ISO 4406 is not exceeded. For the pilot circuit, Target Contamination Class 18/16/13 according to ISO 4406 must not be exceeded.

Hydraulic fluids

Best performance is obtained using mineral-base oil of high quality and cleanness in the hydraulic system. Hydraulic fluids of type HLP (DIN 51524), oil for automatic gear-boxes Type A and engine oil type API CD can be used.

Viscosity, working range 15-380 mm²/s**

Technical information in this catalogue is applicable at an oil viscosity of 30 mm²/s and temperature of 50 °C using nitrile rubber

Weight

Inlet section	8.5 kg	18.7 lb	approx.
Spool section type PC	9.1 kg	20.1 lb	approx.
Spool section type EC	10.8 kg	23.8 lb	approx.
End section	4.1 kg	9.0 lb	approx.
Combo-inlet	11.5 kg	25.4 lb	approx.

** Performance efficiency will be reduced if outside the ideal values. These extreme conditions must be evaluated by the user to establish suitability of the products performance.

Connections

Unless stated otherwise, all standard connections are available in two versions: G-version (BSP pipe thread) for flat seal (type Tredo) as per ISO 228/1 and UNF-version for O-ring seal as per ISO 11926-1.

Connec-tion	In section	G-ver-sion.	UNF-version
P1	inlet section	G 1	1 5/16-12 UN-2B
T1, T2	inlet section	G 1	1 5/16-12 UN-2B
P1	combo-inlet CL	Flange SAE 1 High pres-sure ISO 6162-2	
T1	combo-inlet CL	Flange SAE 1 1/4 Std pressure ISO 6162-1	
T2	combo-inlet CL	G 1	1 5/16-12 UN-2B
LS, PL, PX, PS	inlet, combo-inlet CL	G 1/4	9/16-18 UNF-2B
MP	inlet section	G1/4	9/16-18 UNF-2B
P2	end section	G 1	1 5/16-12 UN-2B
T3	end section	G 1/4	9/16-18 UNF-2B
TP	end section	G1/4	9/16-18 UNF-2B
TP	combo-inlett CL	G 3/8	3/4-16 UNF-2B
PS	end section and combo-inlett CL	G 1/4	9/16-18 UNF-2B
LSP	spool/end section MU	9/16-18 UNF-2A (ORFS pipe end, male)	
LSP	end section	G 3/8	9/16-18 JIC (37°) (male)
YS	inlet, combo-inlet CL	G1/4	9/16-18 JIC (37°) (male)
A, B	spool section	G 3/4	1 1/16-12 UN-2B
PC	spool section	G 1/4	9/16-18 UNF-2B

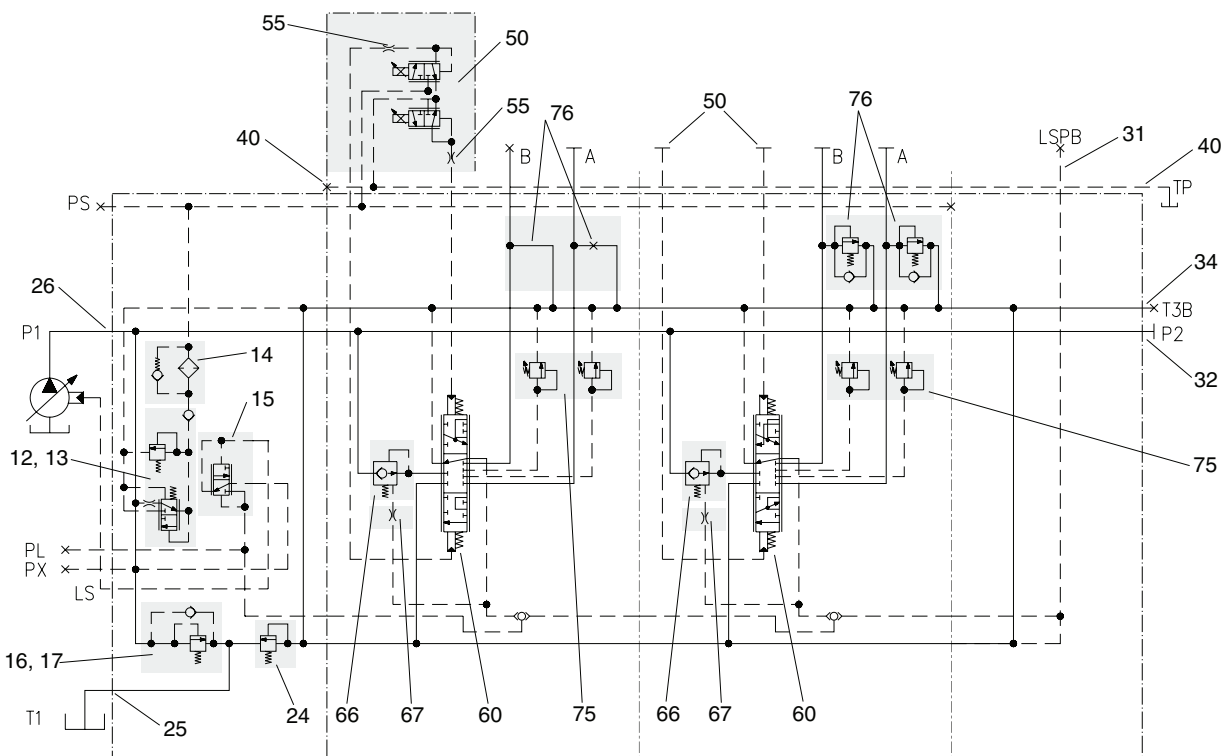

*Hydraulic circuit diagram showing basic functions for K170LS
 Shaded zones are functions or function groups to be found further on in the text.*

The item numbers in the hydraulic circuit diagram and table below refer to the functions or function groups for which different options are available. The valve in the example

above is equipped according to the description below. For other equipment alternatives, see under respective function [item number] in the catalogue.

Item Code	Description	Item Code	Description
12	R Pressure reducing valve with separate safety valve for internal pilot pressure supply.	50	EC Section 1 equipped with proportional electro-hydraulic remote control
13	35 Reduced pressure set to 35 bar	PC	Section 2 equipped with proportional hydraulic remote control
14	S Internal coarse filter for pilot circuit.	55	0,8 Restrictor in pilot supply line
15	LS Load-sensing system	60	EA Section 1 equipped with spool for single acting function. Connect to A-port. B-port plugged
16	PA1 Direct operated main pressure relief valve, with fixed setting.	D	Section 2 equipped with spool for double acting function.
17	280 Pressure setting for main pressure relief valve	66	K1 Pressure compensator with built-in check valve function
24	MF Fixed counter pressure valve	67	0,8 Restriction of load signal to compensator.
25	T1 Tank connection open	75	MR With separate feed reducer on motor ports A and B
26	P1 Pump connection open	76	Y2 Section 1 port A. Service line cavity blocked M-T
31	LSPB Load-signal connection for parallel-connected valve plugged.	X2	Section 1 port B. Service line cavity open M-T
32	P2 Pump connection open		Section 2 ports A and B. Combined port relief and anti-cavitation valve
34	T3B Tank connection plugged		
40	TP Separate tank connection for pilot return		

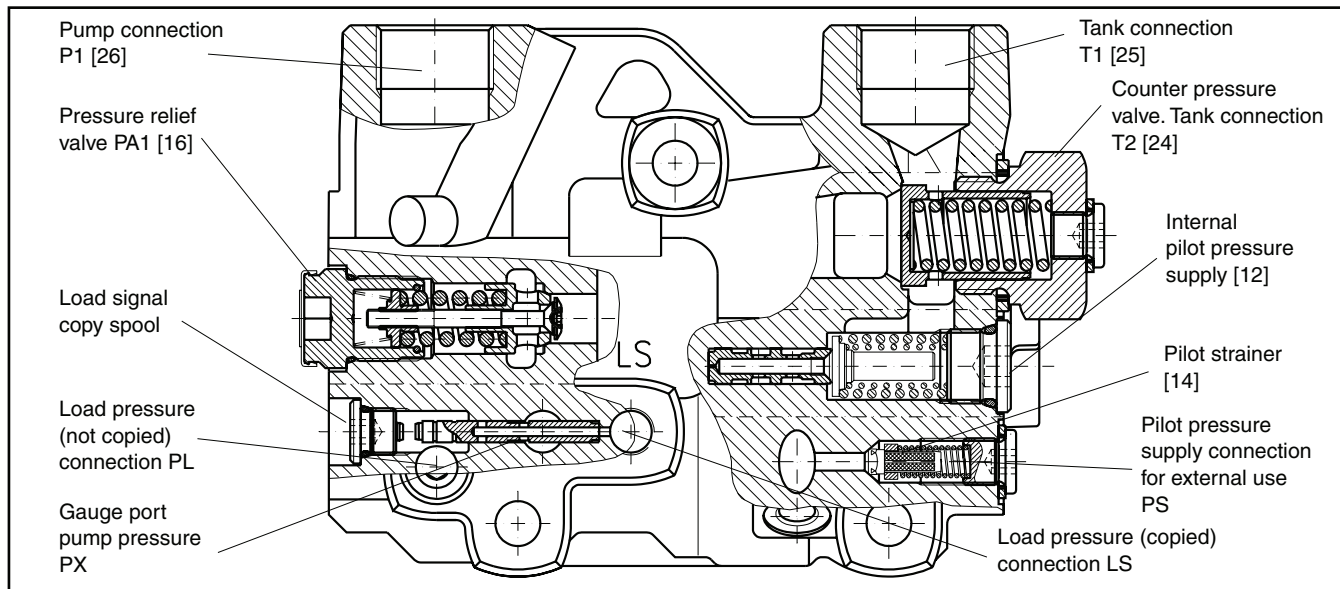

Inlet section [12-29]

The inlet section is equipped with pump (P1) and tank connections (T1, T2), a connection for the load signal to LS pumps (LS), a connection for pilot pressure supply for external use (PS), a gauge point for pump (PX) and load signal pressures (PL). In the basic variant, the pump connection P1 [26] and tank connection

T1 [25] are open, while the other connections are plugged. Functions such as maximum pressure relief, copying of the load signal, pressure reduction for internal pilot-supply, as well as a pilot filter and counter pressure valves can also be integrated into the section.

Internal pilot pressure supply [12]

R Pressure reducer for pilot supply. Internal pilot pressure supply is a valve function, built into the inlet section, which works as both a pressure reducer and a pressure relief valve in the pilot circuit. For safety reasons, the R-cartridge has also been equipped with a separate safety valve function that prevents the maximum permissible reduced pressure from being exceeded. A check valve prevents pilot oil from leaking back to the pump, and therefore enables the pressure in the pilot supply circuit to be maintained in the event of a temporary fall in pump pressure, e.g. during a rapid lowering movement, to secure pilot supply during pump pressure drop, we recommend to connect an accumulator to the PS port. Pilot pressure for external use, e.g. for delivery to PCL4 hydraulic remote control valves, can be tapped from the PS connection on the inlet section.

RX Without pressure reducer for pilot supply.

Pilot pressure [13]

The pilot supply pressure can be set at either 35 or 45 bar.

Pilot filter [14]

S Built in strainer for the pilot supply. Coarse strainer with bypass function in the internal pilot pressure supply. The strainer protects the pilot circuit from dirt, especially during start-up of the system.

YS Adapter for connection of external filter for pilot pressure oil. Enables the pilot circuit to be supplied with cleaner oil compared with the rest of the system. See also filtration, page 7.

Δp (bar) Internal pilot pressure reducer characteristics

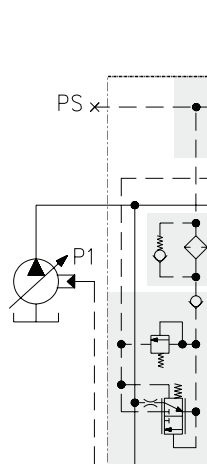
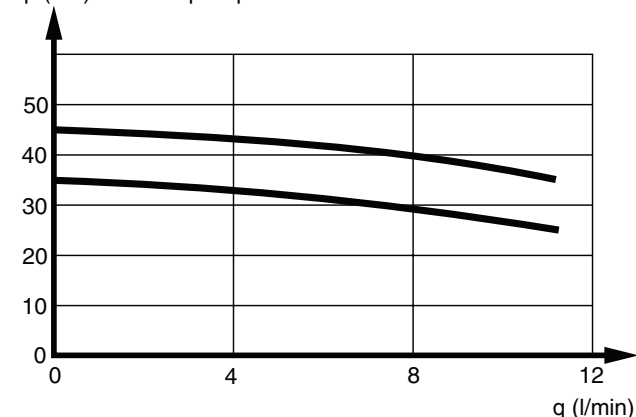

Internal pilot-pressure supply R and pilot strainer S

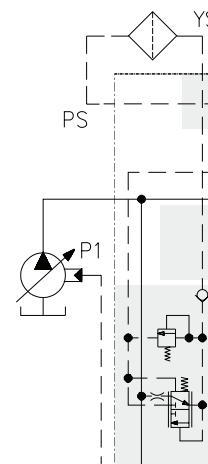

Internal pilot-pressure supply R and adapter YS. (Filter is not supplied with valve)

Load signal system

The load signal system consists of a number of shuttle valves, which compare the load signals from different spool sections and send the highest signal to the connection PL, or to a copying spool in the inlet section.

The system permits a certain consumption in the load signal line to the pump, without the load signal level being affected. This enables simpler system design, with the possibility of installing logic systems in the LS circuit. Thanks to drainage in the pump LS regulator, the system gives better winter operating characteristics with faster response, since the oil in the LS circuit is always warm. In addition to this, the system prevents disruptive micro-sinking of the load in the beginning of the lifting phase.

Inlet section type [15]

The inlet section is available in two variants, one for CP systems and one for systems with LS pumps.

- LS** Inlet section for systems with LS pump.
 The system is equipped with a directly controlled pressure relief valve, PA1[16], which protects the pump and inlet side of the valve. The LS is always equipped with a load-signal copy function.
- LS3** Inlet section for constant pressure systems.
 Same as LS but without load-signal copy function, LS.
- A025** Inlet section for un-loading constant pressure systems (CPU).
- CL** Combi inlet used as mid-inlet when L90 and K170 are assembled together. This works as 'adapter plate' between valves and replaces inlet sections from both valves.

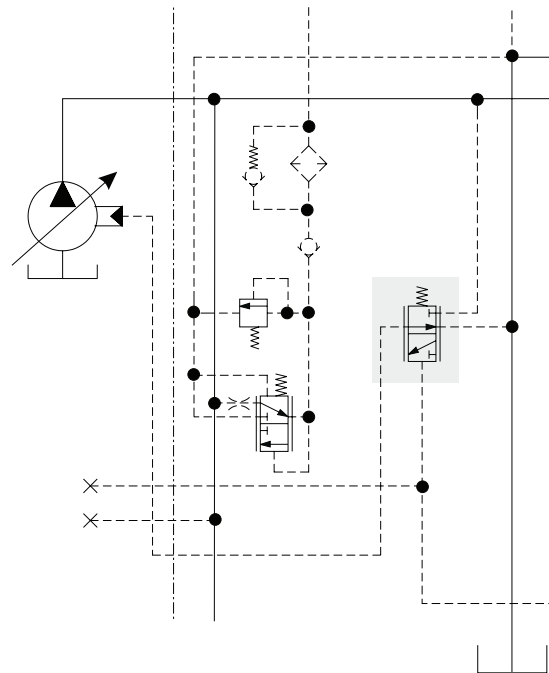

Inlet section type A025 for un-loading constant pressure systems (CPU).

Pressure relief valve [16]

The inlet section is normally equipped with a pressure relief valve to protect the pump and valve from pressure peaks in the system.

- PA1** Direct acting port relief valve with very fast opening sequence and good pressure characteristics. The replaceable cartridge is factory set. The cartridge has a make-up function, which means that oil is able to flow from the tank gallery to the pump gallery in the event of underpressure in the pump circuit. For setting values, please see Pressure settings [17].
- Y1** Without relief valve.
 Plug which can replace the pressure relief valve. The Y1-plug blocks the connection between the pump and tank completely.

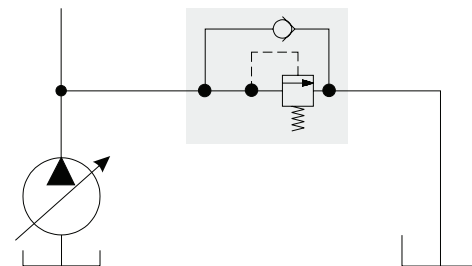

Pressure relief valve PA1

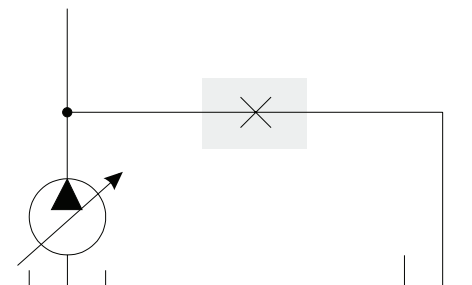

Without relief valve Y1

Pressure setting [17]

Pressure setting for PA1 [16]

The PA1 direct acting pressure relief valve is delivered with a fixed setting. The standard settings (in bar) available are:

Setting pressure in bar: 50, 63, 80, 100, 125, 140, 160, 175, 190, 210, 230, 240, 250, 260, 280, 300, 330.

PA1 needs to be set 20 bar above pump pressure.

See also technical data, page 6-7.

Tank connection T2 [24]

T2B Alternative tank connection T2 plugged. Common variant.

T2 Alternative tank connection T2 open.

Counter pressure valve

The counter pressure valve, which raises the pressure in the valve's tank gallery, is placed in the inlet section. It is available in two versions: MF with fixed setting and MP with pilot-controlled setting.

By raising the counter pressure, the anti-cavitation characteristics of the K170LS are improved still further. This might, for example, be desirable in situations where make-up flow is directed into the large side of the cylinder during the lowering of loads. Good make-up characteristics eliminate the risk of cavitation and reduce the risk of damage to the cylinder seals. They are also important for functions in which a lowering movement changes to a lifting movement without a time delay.

The pilot-operated version gives counter pressure only when it receives a signal. It can be employed in such a way that the signal to the counter pressure valve is connected only to the spool-actuator signal(s) controlling the lowering movement(s) that need extra counter pressure. In this way, unnecessary losses can be avoided.

MF Counter pressure valve factory set to give 5 bar counter pressure at a flow of 20 l/min.

MP Pilot operated counter pressure valve for external control of counter pressure between 0 and 36 bar. Tank connection T1 [25] must be open and tank connection T3 must be plugged (T3B [34]).

The MP pilot operated variant only gives a counter pressure upon receipt of signal. This can be exploited so that the signal to the counter pressure valve is connected only to the spool actuating signal(s) controlling the lowering movement(s) that need an extra counter pressure, thus avoiding unnecessary losses. Max permitted signal pressure is 30 bar. The relationship between pressure and signal is 1.2:1.

Tank connection T1 [25]

T1 Tank connection T1 is open. Common variant.

T1B Tank connection T1 is blocked.

Pump connection P1 [26]

P1 Pump connection P1 is open. Common variant.

P1B Pump connection P1 is plugged.

Δp (bar) Pressure relief characteristics

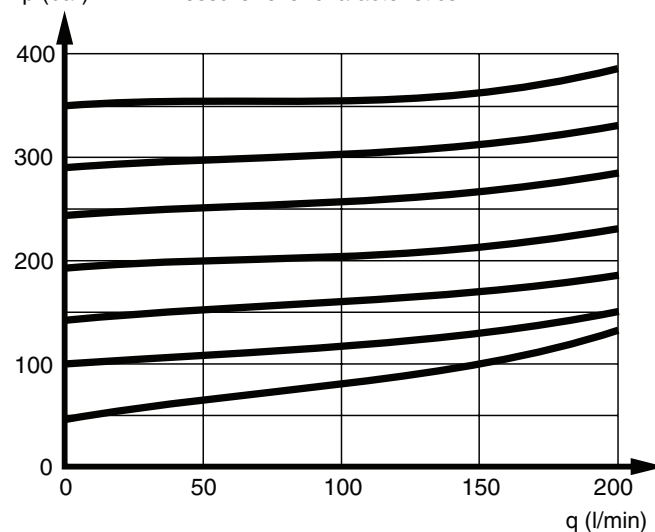

Δp (bar) Anti-cavitation characteristics

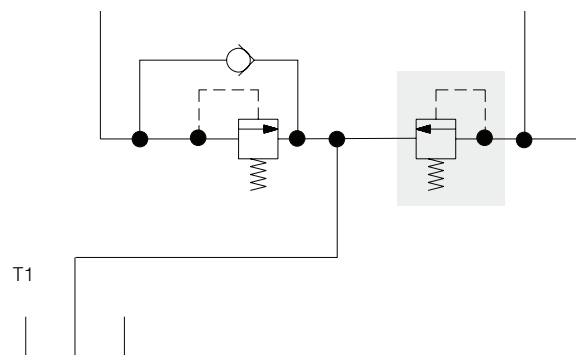
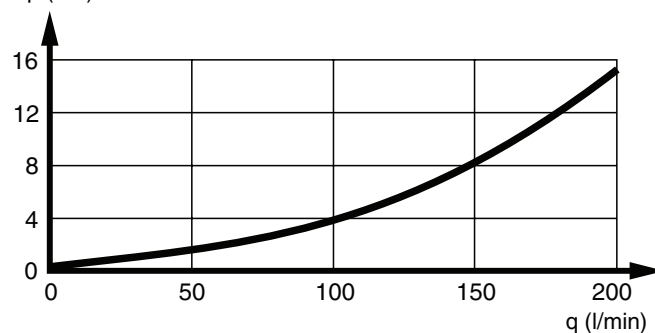

Counter pressure valve MF

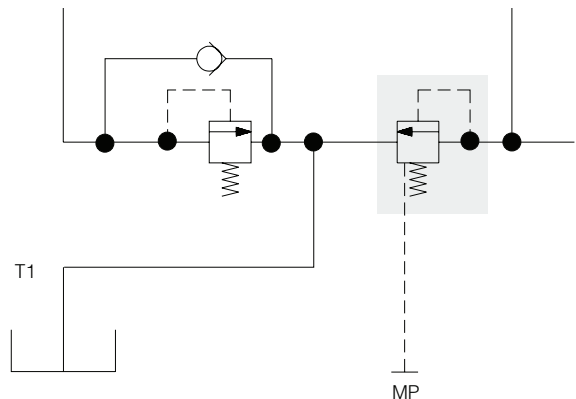

Pilot operated counter pressure valve MP

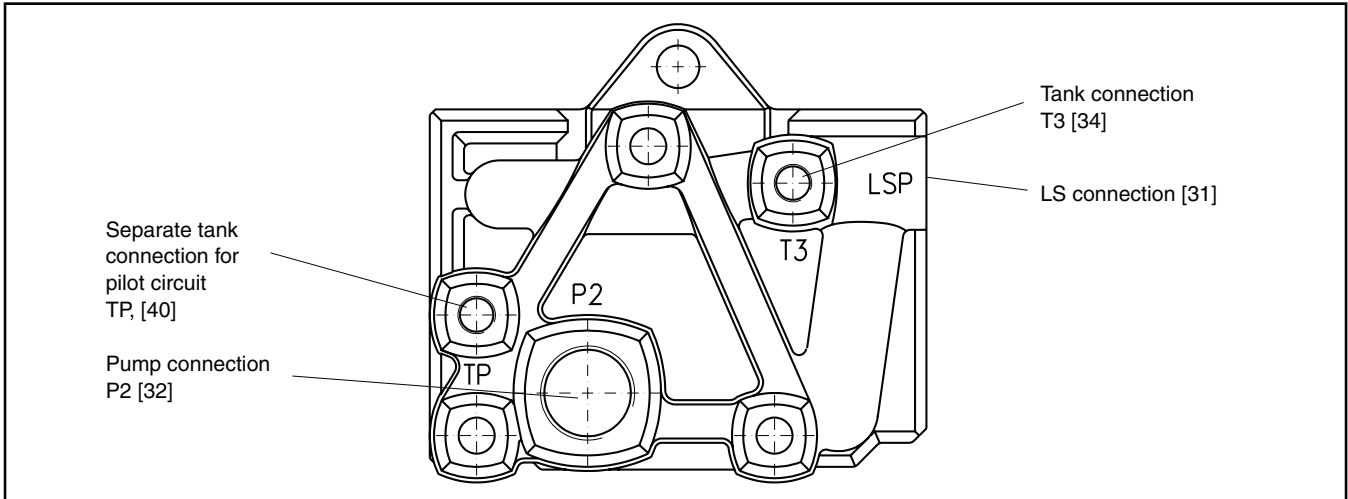

End section [30 - 44]

The end section is available in two variants, one with all connections machined and one without machined connections for pump (P2), and tank (T3).

In the basic variant, the LS connection LSP [31], pump connection P2 [32] and tank connection T3 [34] are plugged.

In addition to the two standard models, there is a special adapter plate (AP) which is used when the valve flanges against

an L90LS valve. The adapter plate contains only the pilot tank connection and through channels which connect the pump, tank, pilot pump, pilot tank and LS channels of the K170LS and L90LS valves, respectively. Thus, the pump and tank need only be connected to the K170LS valve.

The valves are turned so that the adapter plate serves as a common end plate for the K170LS and L90LS.

End section [30]

US Standard end section.

AP Adapter plate for connection of L90 and K170 together. Works as the common end plate for both valves. Choose when APE170 or API170 is specified in L90.

LS-connection [31]

LSP Port open for connection of LS-signal from other valve. This connection is used to receive the load signal from a parallel connected valve.

LSPB Port for LS signal from other valve plugged. LS signal is internally drained.

Pump connection P2 [32]

P2 Alternative pump connection in rear face. The connection can, for example, be used to feed valves located to the rear, or for double feeding of the valve in applications where many functions with very high flow demands are operated simultaneously. The connection can also be used in situations where feeding from the rear face is the most suitable option in terms of space available.

P2B Alternative pump connection plugged. Common variant.

Tank connection T3 [34]

T3 Tank connection T3 is open.

T3B Tank connection T3 is plugged. Common variant.

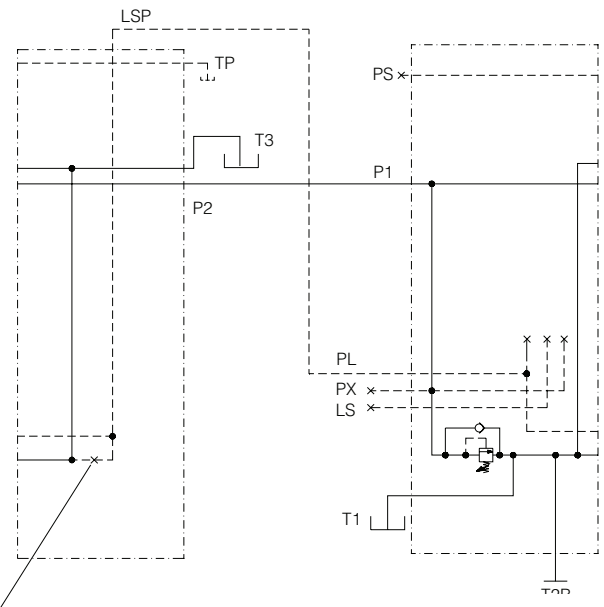

Only with LSP [31]

In the case of parallel connected valves, the PL connection load-sensing signal in the last valve passes to the LSP connection in the first valve. The rear valve can be fed with pump oil, by connecting P2 and P1.

Separate tank connection for the pilot circuit [40]

TP Separate tank connection for the pilot circuit is open. The connection to the main tank gallery of the directional valve is blocked in the inlet section. The function is recommended for systems in which there is a risk of dynamic pressure fluctuations in the tank line, which cause fluctuations in the pilot circuit when there is a common tank line.

NB! TP connection can not be plugged.

/ Not prepared for separate pilot return.

Spool section with actuator type PC

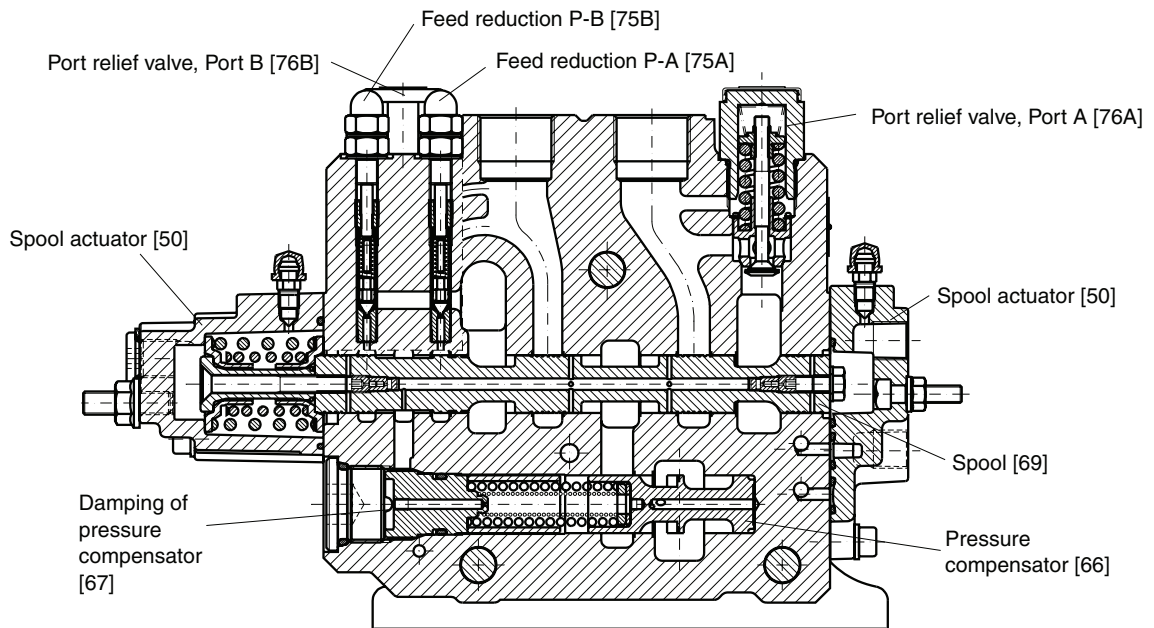

Spool section [45-89]

The K170LS directional valve is stackable and can be delivered in combinations of 1 to 9 spool sections. Each section can be equipped individually with a large number of optional functions, spools and spool actuators for optimum adaptation to the application and controlled function.

Material design [48]

- S** Spool section in nodular-iron design, (Max 330 bar in pump port and max 350 bar in service port).

Spool actuators [50]

PC, PCH - Hydraulic spool actuator

- PC** Hydraulic spool actuation.
- PCH** Hydraulic spool actuation with manual operation.
- The PC and PCH are proportional, hydraulically controlled spool actuators with spring centring to the neutral position. They are intended to be hydraulically remote controlled by PCL4.
- When choosing a control pressure for the PCL4, its starting pressure should be approx. 1 bar lower than that of the directional valve, in order to ensure gentle starting and stopping. The pilot pressure for the control pressure valve can be connected to the PS port for the internal pilot pressure supply in the inlet section of the directional valve.
- | | | |
|------------|------------------------------|----------|
| PC | Control pressure, breakaway* | 5.6 bar |
| | Control pressure, final* | 20.5 bar |
| PCH | Control pressure, breakaway* | 5 bar |
| | Control pressure, final* | 21 bar |
- Permissible pressure in pilot cap max. 50 bar
- Connections: G1/4 or 9/16-18 UNF

* The breakaway pressure is the pressure needed for the directional valve to open the connection "pump to service port". The final pressure is the lowest pressure needed to effect full actuation of a spool in the directional valve. This data must be taken into consideration when choosing control units, since the opening pressure of the control unit must be lower than the breakaway pressure of the spool actuator in order to avoid jerky starting and stopping. However, the control unit's final pressure must be higher than the final pressure of the directional valve in order to ensure that the spools can be fully actuated.

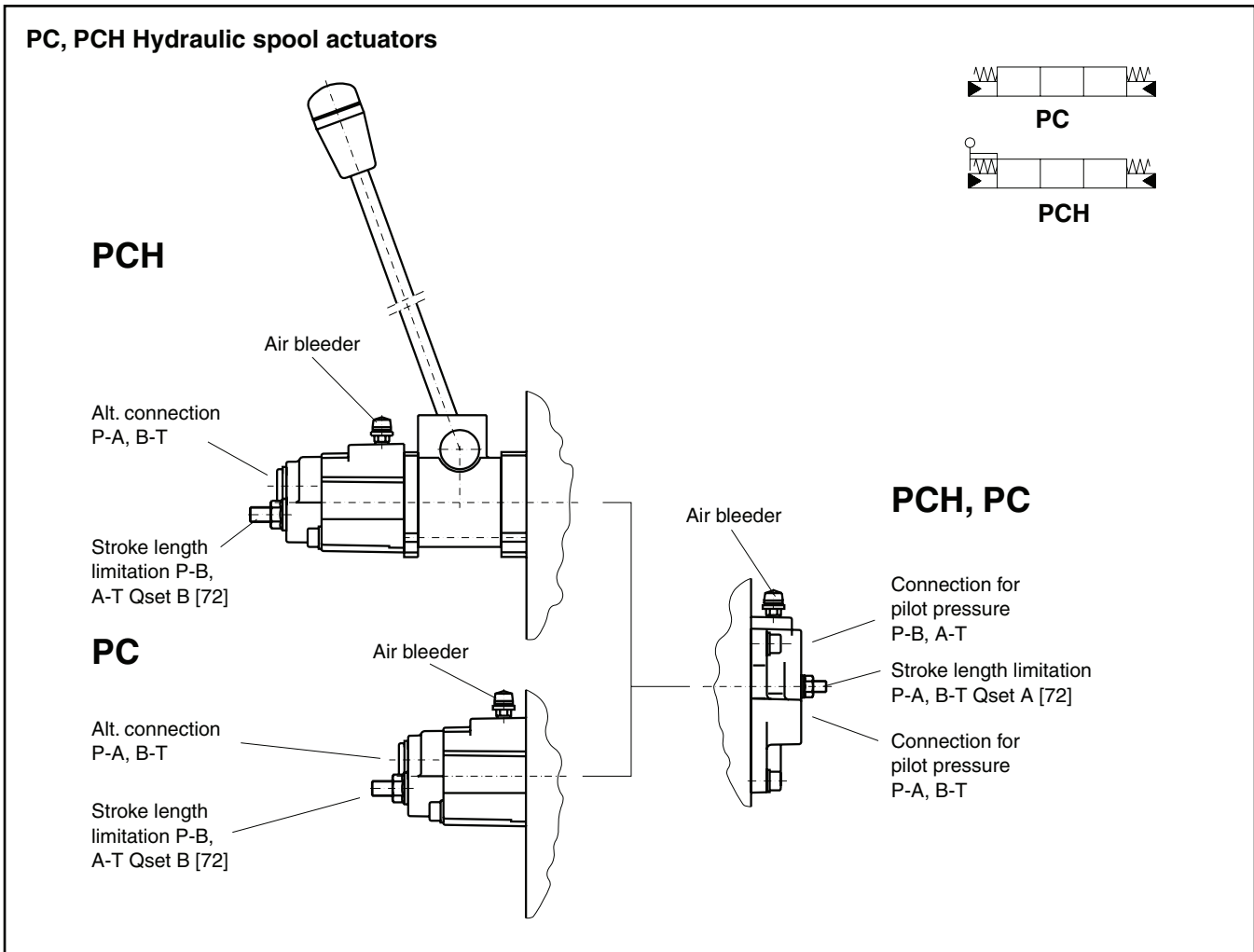

Electro-hydraulic proportional spool actuator

EC/ECS Electro-hydraulic spool actuator

The EC/ECS are proportional, electro-hydraulically controlled spool actuators with spring centering to neutral. They are intended to be controlled remotely by the IQAN control systems. Pilot-pressure oil is led to the spool actuators through internal ducts in the directional valve. This means that only the electric cables from the control system to the converter valve needs to be connected externally.

Control current for 12 V
 Breakaway* min. 570 mA
 Fully actuated max. 1250 mA

Control current for 24V
 Breakaway* min. 290 mA
 Fully actuated max. 650 mA

The control current must be regulated for temperature compensation and with ripple to minimise hysteresis. Measuring connections: G1/4 or 9/16-18 UNF

EC as ECS but with manual over-ride and air-bleed screw in the converter valve.

ECH Electro-hydraulic spool actuator with lever for direct control

The ECH spool actuator can be operated directly and steplessly by a supplementary local lever (optional). Other data as for ECS to the left.

Connector types [56]

A AMP Junior-Timer type C

D Deutsch type DT06-2P

* The breakaway current refers to the current needed for the directional valve to open the connection "pump to service port". The final current is the lowest current needed to effect full actuation of a spool in the directional valve. This data must be taken into consideration when choosing control units, since the opening current of the control unit must be lower than the breakaway current of the spool actuator in order to avoid jerky starting and stopping. However, the control unit's final current must be higher than the final current of the directional valve in order to ensure that the spools can be fully actuated.

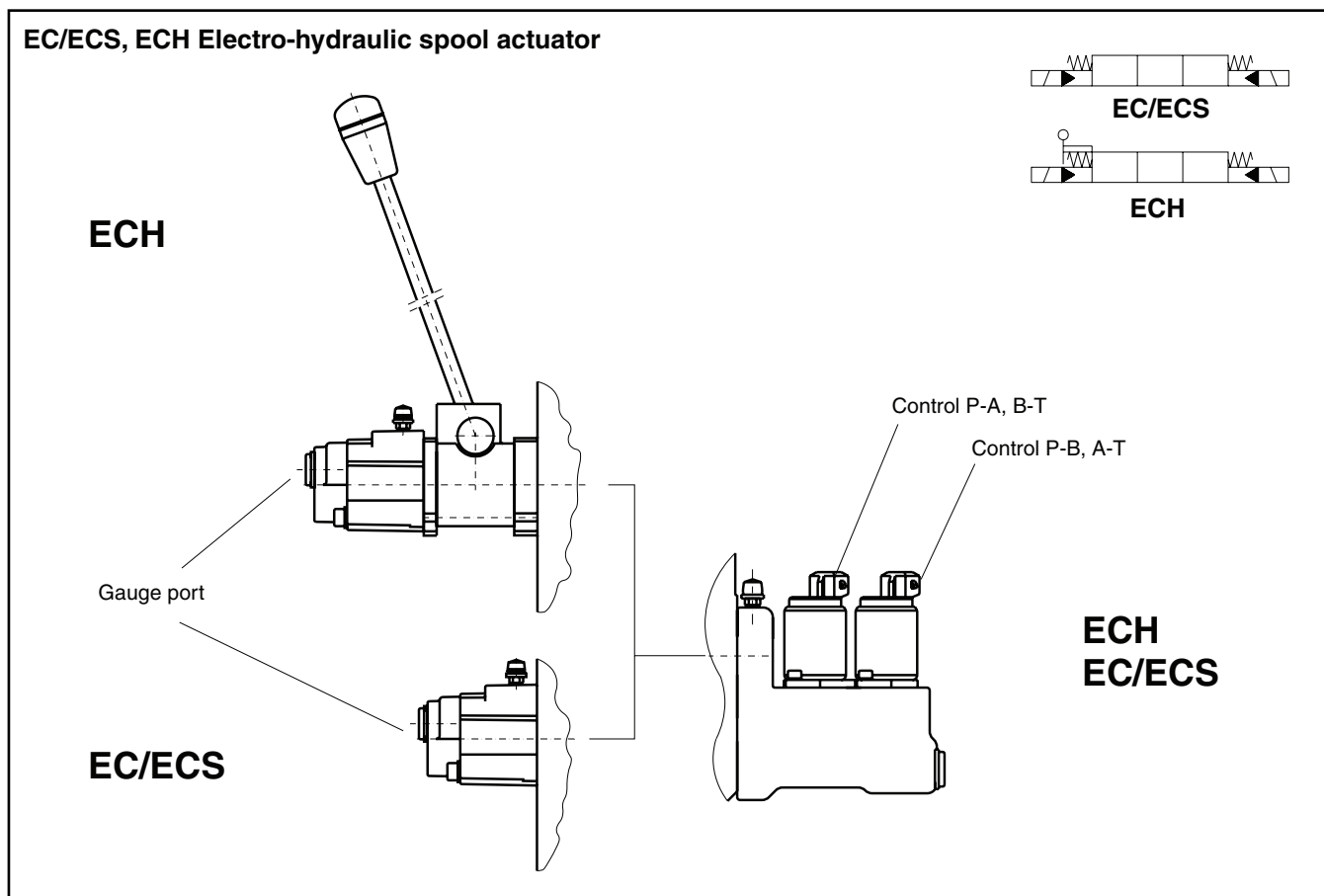

Pilot restrictor [55 A,B]

To give gentle remote control, the EC, ECS, ECH, PC and PCH spool actuators are fitted with pilot restrictors, which can be chosen individually for each service port. The restrictor gives a kind of ramp function.

For the EC, ECS and ECH, the following options are available:

- / Without pilot restrictor
- 0.45** 0.45 mm pilot restrictor
- 0.6** 0.6 mm pilot restrictor
- 0.7** 0.7 mm pilot restrictor
- 0.8** 0.8 mm pilot restrictor (Normal)
- 0.9** 0.9 mm pilot restrictor
- 1.0** 1.0 mm pilot restrictor
- 1.1** 1.1 mm pilot restrictor
- 1.2** 1.2 mm pilot restrictor
- 1.3** 1.3 mm pilot restrictor
- 1.4** 1.4 mm pilot restrictor
- 1.5** 1.5 mm pilot restrictor

For PC, PCH the following options are available:

- / Without pilot restrictor (Normal)
- 0.6** 0.6 mm pilot restrictor
- 0.8** 0.8 mm pilot restrictor
- 0.9** 0.9 mm pilot restrictor
- 1.0** 1.0 mm pilot restrictor
- 1.1** 1.1 mm pilot restrictor
- 1.2** 1.2 mm pilot restrictor
- 1.3** 1.3 mm pilot restrictor
- 1.4** 1.4 mm pilot restrictor
- 1.5** 1.5 mm pilot restrictor

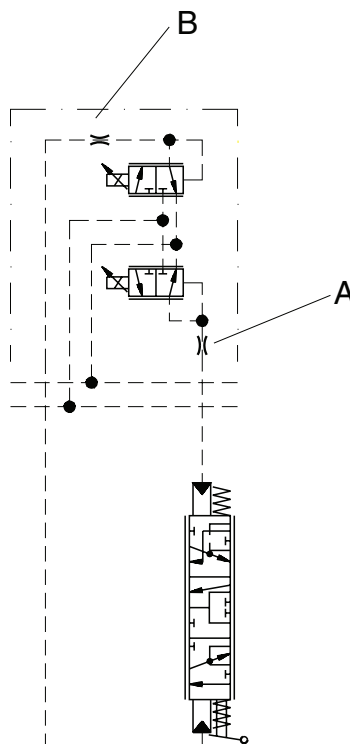

Pilot restrictor for EC and ECH spool actuators

Spool selection [60-74]

Spool options

The spool is the most important link between the operator's activation of a lever unit and the movement of the controlled function. For this reason, Parker makes a wide range of standard spools to meet many different function-specific demands. Spool selection is effected with the aid of a computerized specification program, using a series of different parameters to determine the optimum spool for the job.

Spool function [60]

There are many spool variants which are adapted for different flows, load conditions and actuator area ratios. The spools are also available with different degrees of force feedback from the service ports A and/or B.

- D** Double-acting spool for, e.g. double-acting cylinders. Blocked in the neutral position.
- Dm** Double-acting spool with drainage of service ports A and B to tank, which prevents pressure build up in the neutral position. The spool is used as a double spool in combination with a double over-centre valve.
- Da** Double-acting spool with drainage of service port A to tank, which prevents pressure build up in service port A in the neutral position.
- Db** Double-acting spool with drainage of service port B to tank, which prevents pressure build up in service port B in the neutral position.
- EA** Single-action spool for, e.g. single-acting cylinder. Blocked in neutral position. Service port B blocked.
- EA3** Single-action spool for, e.g. single-acting cylinders. Blocked in neutral position. Service port B blocked during lifting function. Lowering function at both service ports A and B.
- EB** Single-action spool for, e.g. single-acting cylinders. Blocked in neutral position. Service port A blocked.
- M** Double-acting spool for, e.g. hydraulic motors. Floating function in neutral position.
- MA** Double-acting spool for, e.g. hydraulic motors. Floating function in neutral position, service port A to Tank.
- MB** Double-acting spool for, e.g. hydraulic motors. Floating function in neutral position, service port B to Tank.
- CB** Regenerative spool for rapid feeding of cylinder via service port B. The large side of the cylinder is connected to service port B.

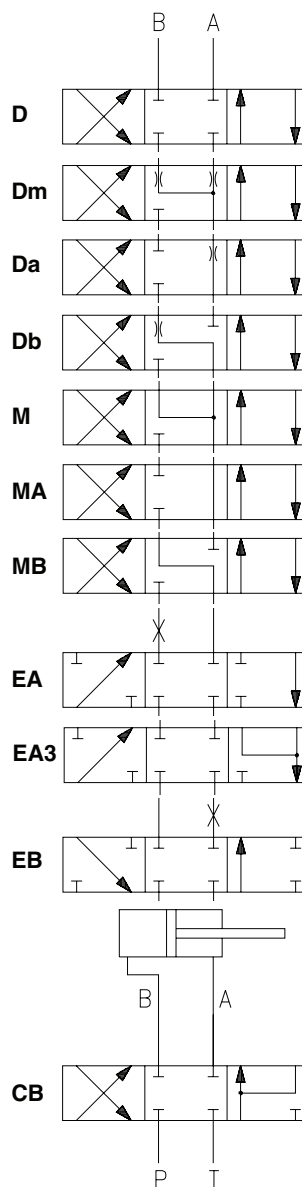

Flow requirement [61 A,B]

The K170LS directional valve has a range of optimized spool designs for nominal flows up to 170 l/min when the section is equipped with an individual pressure compensator, K1 [66]. See "Pressure compensator and/or load-hold check valve [66]" for flow with other compensators.

Without an individual pressure compensator, flows up to 220 l/min are obtainable, depending on the pre-set regulating difference in the LS pump.

The desired flow to the service ports A and B is entered in the ordering documentation. Parker's computerized specification system then selects spools to give at least the flow required, also taking other parameters into account.

The maximum flow is then set by limiting the spool stroke by means of adjustment screws on the spool actuator or, in the case of electro-hydraulic remote control, by setting the maximum current.

See "Flow settings" [72] for details on factory setting of maximum flow.

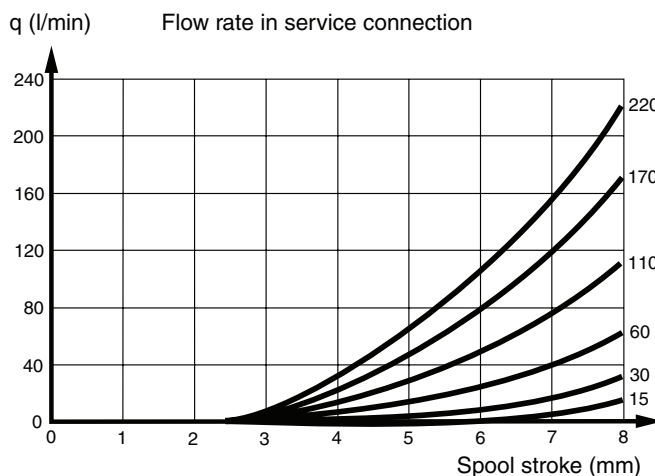

Typical curves showing flow as a function of spool stroke

Area relationship [62]

The area relationship for a section is calculated by dividing the cylinder area that is connected to the service port B by the area that is connected to the service port A. When the larger side of the cylinder is connected to the service port A, the relationship is less than 1. The area relationship for a motor is 1.

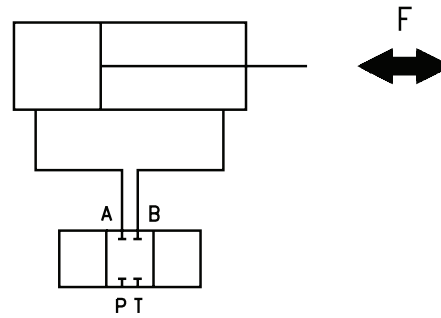

LAB - Load can change between the A- and B-port.

Load characteristics [63]

The character of the load can be selected according to five typical cases. This information is entered so that the spool can be given the best possible adaptation to the intended application.

- LAB** Lift load can change between service ports A and B.
- LA** Lift load normally on service port A only.
- LB** Lift load normally on service port B only.
- LN** No or low lift load on service ports A and B.
- S** Slewing function.

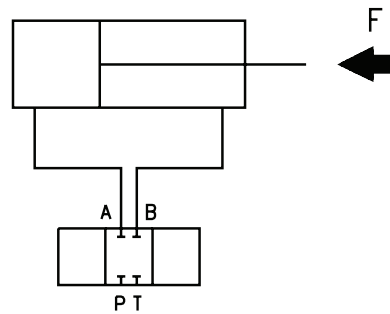

LA - Load normally on A- port only.

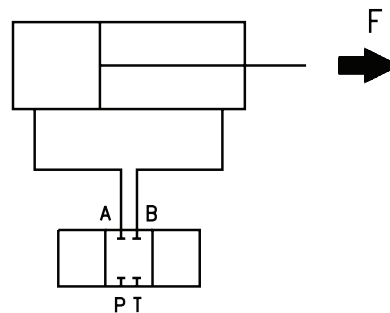

LB - Load normally on B- port only.

Force feedback [64 A,B]

The K170LS is available with a force-feedback option, which enables the positive sense of force control from CFO systems to be transmitted to LS systems, thus enabling force-control characteristics to be incorporated in individual valve sections. With force control, the operator is better able to sense the increase in machine load when a hard obstacle is met, e.g. in digging operations.

Force feed-back also gives a kind of ramp function, which results in more gentle transitions during speed changes. This in turn has a stabilizing effect on the hydraulic system, and the machine operating characteristics become smoother. Both these characteristics are important, especially for slewing functions and similar movements. With force feedback, machine wear is reduced and efficiency increases.

The section can be equipped with force feedback for the service ports A and B individually. The degree of force feedback can be chosen from three levels. The higher the level of force feedback, the greater the reduction in the function's speed upon increasing resistance for the same lever stroke. It follows from this that the lever must be moved further in order for the speed to remain the same when the load is increasing.

- /** No force feedback
- FN** Normal level of force feedback
- FH** High level of force feedback
- FL** Low level of force feedback

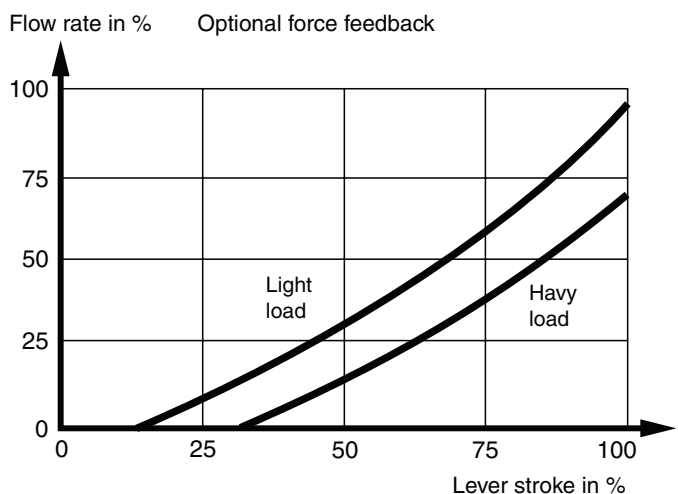

Force feedback

Pressure compensator and/or load-hold check valve [66]

Pressure compensators

The primary purpose of pressure compensation is to maintain a constant flow rate to a function, regardless of pressure variations in the system. The facility is of special value in lifting functions.

Excellent simultaneous operation characteristics

In cases where several machine functions are operated simultaneously, the spool sections in the K170LS can be equipped with individual, integrated pressure compensators. Subject to available pump capacity, sections so equipped will deliver the pre-determined constant flow regardless of other simultaneously operated functions, and regardless of variations in load or feed pressure. Parker integrated pressure compensators have a very quick response time and incorporate built-in load-hold check valves.

Increased or reduced function speed where required

To meet demands for exact speed in certain functions, Parker integrated pressure compensators comes in a number of fixed variants that give flow rates from nominal to +55% through the selfsame spool (see K1 to KN1 below). To accommodate changing operating conditions, a variant that can be adjusted on site to give $\pm 20\%$ of nominal flow is also available (see KS below).

- K1** Fixed pressure compensator with load-hold check valve. The spool gives nominal flow.
- K2** Fixed pressure compensator with load-hold check valve. The spool gives 20% more than nominal flow.
- K3** Fixed pressure compensator with load-hold check valve. The spool gives 55% more than nominal flow. N.B. Pump must deliver a pressure of at least $\Delta p=30$ bar. (30 bar above load signal reported to pump regulator.)
- KN1** Fixed pressure compensator with extra fast load-hold check valve. The spool gives 15% more than nominal flow.
- KS** Adjustable pressure compensator with load-hold check valve. The spool gives $\pm 20\%$ of nominal flow.
- N1** Load-hold check valve.
- X1** Prepared for compensator and load-hold check valve.

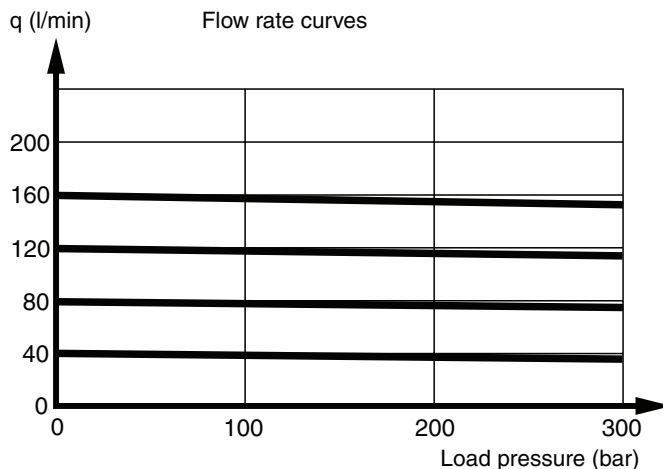

Load independent flow with pressure compensator

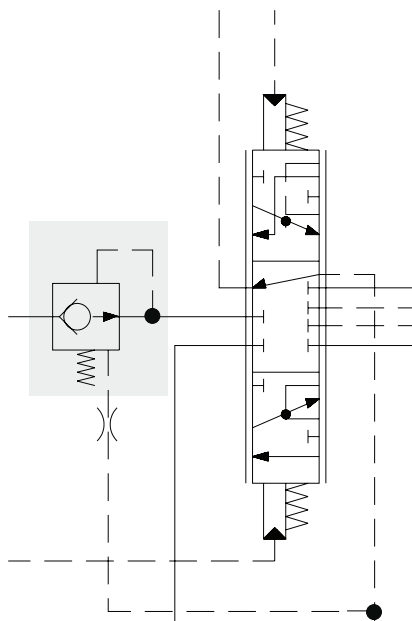

Pressure compensator for constant flow in service port (KN1).

Damping of pressure compensator [67]

The load-signal restrictor affects the response of the pressure compensator.

- 0.6 Alternative LS restrictor for comp. Ø0.6 mm
- 0.8 Recommended LS restrictor for comp. Ø0.8 mm
- 1.0 Alternative LS restrictor for comp. Ø1.0 mm

Spool designation [69]

The task of spool selection can be submitted to Parker's computerized specification program, which adapts the spool to match the specific demands of each function, thus optimizing the spool.

The information given at positions 61, 62, 63, 64 and 66 therefore makes up part of the basis for the choice of spool.

Flow settings [72]

With PC and PCH spool actuators, flow limitation over the spool to motor ports A and B can be effected by means of mechanical limitation of the spool stroke length.

Qset When the spool section is equipped with a PC or PCH spool actuator, it can be delivered with a factory-set maximum flow rate. Setting is carried out according to the stated flow requirements to the A-and B-ports [61 A, B].

Qset A When the spool section is equipped with a PC or PCH spool actuator, it can be delivered with a factory-set maximum flow rate. Setting is carried out according to the stated flow requirements to the A-ports [61 A].

Qset B When the spool section is equipped with a PC or PCH spool actuator, it can be delivered with a factory-set maximum flow rate. Setting is carried out according to the stated flow requirements to the B-ports [61B].

When setting the flow rates for sections without pressure compensators in systems with LS pumps, the flow setting is made with a Δp of 20 bar between the pump pressure in PX and the load signal in PL, at full flow take-up. For details on setting the flow for PC spool actuators, see page 14.

Feed reduction valves [75]

Any section in the K170LS valve can be equipped with individual feed reducing valves for the service ports A and B. These are used for those functions in the system which require a lower maximum pressure than the normal operating pressure of the system. The reducing valve is infinitely adjustable between 30 and 330 bar. It serves to reduce the pump pressure so that the feed pressure in the section in which it is fitted does not exceed the pre-set value.

The use of feed reducing valves enables the pressure to be limited without using any more than a pilot flow (<2 l/min).

In the case of feed reduction, the section must be fitted with a pressure compensator. Since the feed reducing valve is a two-way valve, pressure shocks that arise after the feed reducing valve must be limited with the aid of a port relief valve. The pressure setting on the port relief valve [76 A,B] can be set as low as 10 bar above reducer setting.

Setting of feed reduction in the A-port [75A]

Setting values for the A-port are from 30 to 330 bar.

Setting of feed reduction in the B-port [75B]

Setting values for the B-port are from 30 to 330 bar.

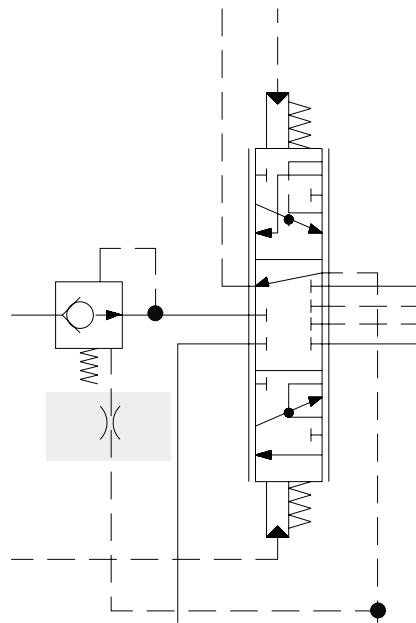

Restrictor for damping of pressure compensator.

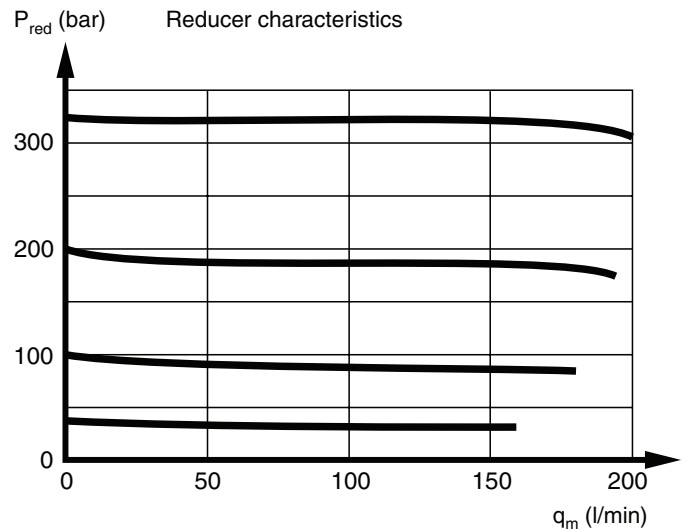

P_{red} = Reduced pressure
 q_m = Flow at service port

Port relief and/or anti-cavitation valves [76 A,B]

A specially designed cartridge valve is used as a port relief and anti-cavitation valve, PA, in the service ports. Its function is to protect the valve and consumer from pressure peaks and excessive pressure in the system. The very rapid opening sequence and good pressure characteristics make the cartridge valve an excellent port relief valve. The anti-cavitation valve causes oil to flow from the tank gallery to the service port side in the event of under-pressure in the service ports.

Separate anti-cavitation valve in service ports

As an alternative to the port relief valve, the service ports can be fitted with anti-cavitation check valves. These enable oil to flow from the tank gallery to the service port side in the event of under-pressure.

The connection between tank and service port can also be blocked using an Y2-plug.

Anti cavitation characteristics

The curve shows the pressure drop between tank connection and service port when the PA or N2 cartridge is used as an anti-cavitation valve.

- X2** Service port open to tank.
- Y2** Service port blocked to tank with plug.
- N2** Service ports of section equipped with anti-cavitation valve.
- 50-350** Standard pressure settings for port relief valves (PA) in bar:
 50, 63, 80, 100, 125, 140, 160, 175, 190, 210, 230, 240, 250, 260, 270, 280, 300, 330 and 350.

The pressure setting on the port relief valve can be set as low as 10 bar above reducer setting. [75 A,B].

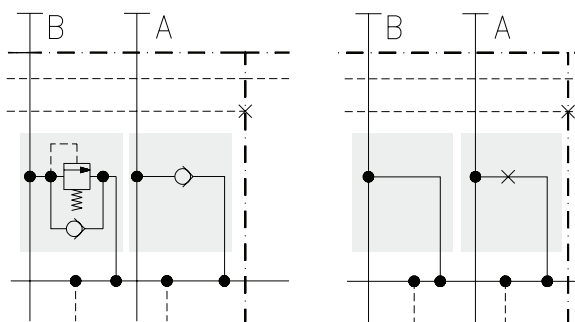
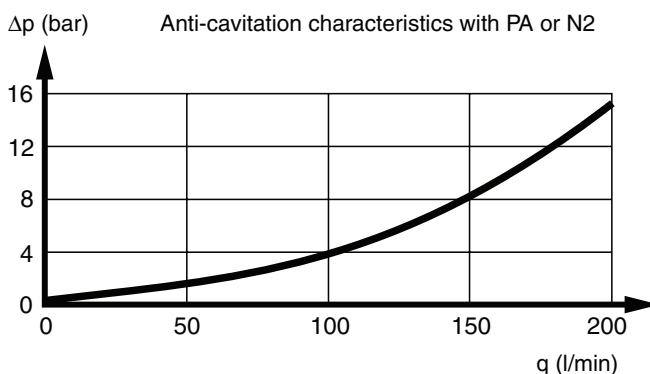
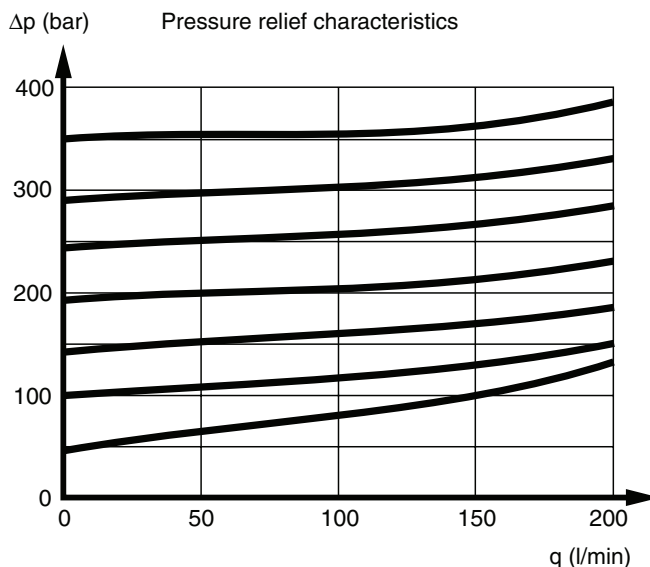

Port B is equipped with a combined port relief valve and anti-cavitation valve. (PA) Port A is equipped with an anti-cavitation valve (N2).

Port B is open to tank (X2) and port A has no tank connection (Y2).

Function block [90-99]

The K170LS can be equipped with function blocks (manifolds) that enables complete system solutions to be integrated into the valve.

Please contact Parker for more details on integrated system solutions. In addition to standard blocks, Parker's custom-builds function blocks to meet special system demands.

Below is an example of a specially designed function block for a specific customer.

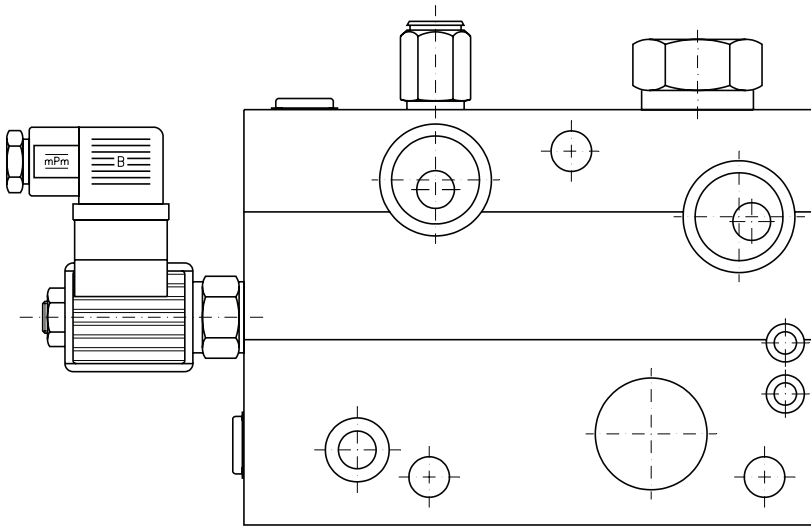

This block, like most of our function blocks, is built up using standard cartridge valves. Only the block itself is unique.

Connectors

Connectors are not included with spool actuators, and should be ordered separately as per the lists below.

Spool actuators EC/ECS/ECH

Suitable connectors are the:
AMP Junior-Timer type C, 963040-3
or Bosch 1 928 402 404.

Assembly kits complete	1 off	393000K822
with pins and seals can be	10 off	393000K825
ordered using the kit	50 off	393000K826
numbers opposite.	100 off	393000K827

(inch)

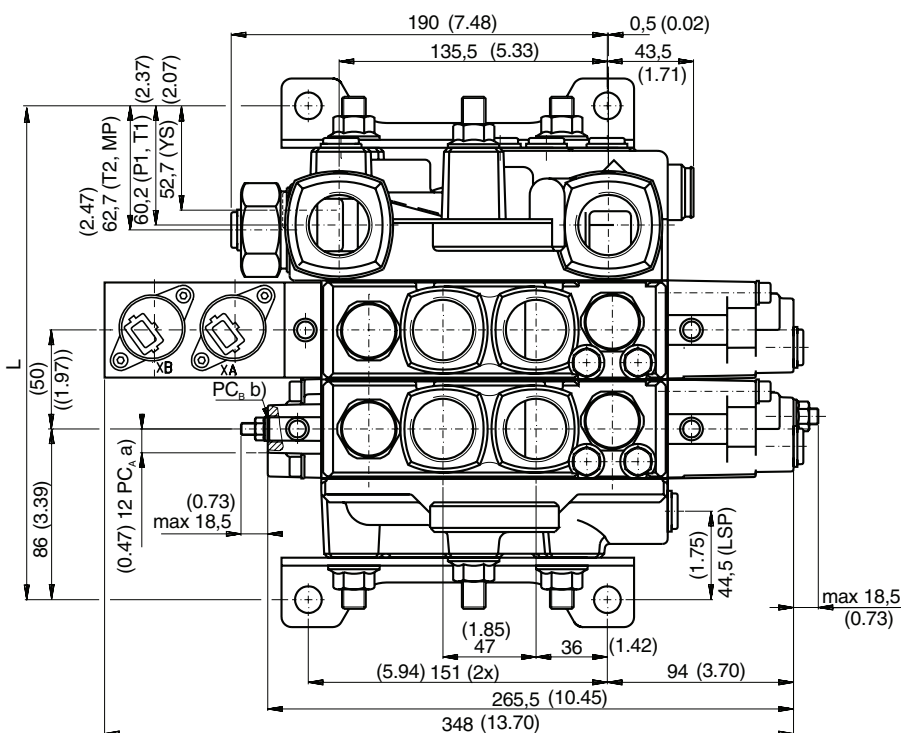
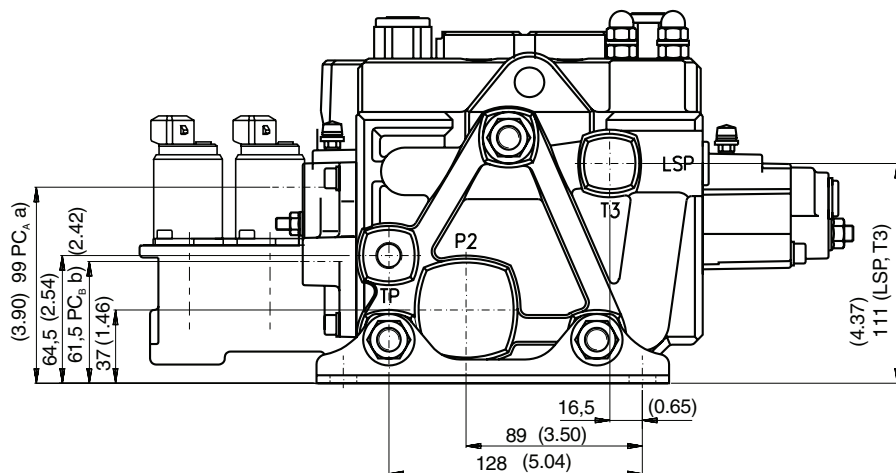
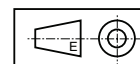

No. of Sections	L mm	L inch
1	200	7.87
2	250	9.84
3	300	11.81
4	350	13.78
5	400	15.75
6	450	17.72
7	500	19.69
8	550	21.65
9	600	23.62

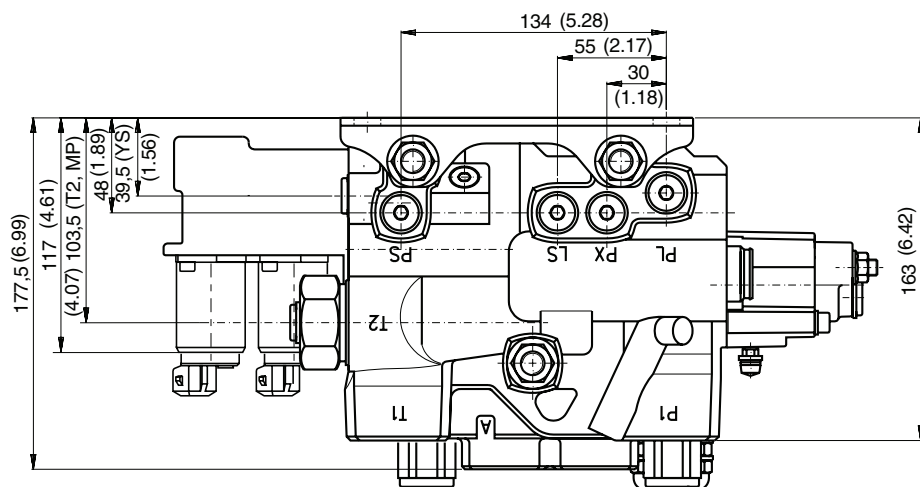

a) Pilot-pressure connection PC_A activates service port A
 b) Pilot-pressure connection PC_B activates service port B

Parker Worldwide

AE – UAE, Dubai
Tel: +971 4 812 7100
parker.me@parker.com

AR – Argentina, Buenos Aires
Tel: +54 3327 44 4129

AT – Austria, Wiener Neustadt
Tel: +43 (0)2622 23501-0
parker.austria@parker.com

AT – Eastern Europe, Wiener Neustadt
Tel: +43 (0)2622 23501 970
parker.easteurope@parker.com

AU – Australia, Castle Hill
Tel: +61 (0)2-9634 7777

AZ – Azerbaijan, Baku
Tel: +994 50 2233 458
parker.azerbaijan@parker.com

BE/LU – Belgium, Nivelles
Tel: +32 (0)67 280 900
parker.belgium@parker.com

BR – Brazil, Cachoeirinha RS
Tel: +55 51 3470 9144

BY – Belarus, Minsk
Tel: +375 17 209 9399
parker.belarus@parker.com

CA – Canada, Milton, Ontario
Tel: +1 905 693 3000

CH – Switzerland, Etoy
Tel: +41 (0) 21 821 02 30
parker.switzerland@parker.com

CN – China, Shanghai
Tel: +86 21 5031 2525

CZ – Czech Republic, Klecany
Tel: +420 284 083 111
parker.czechrepublic@parker.com

DE – Germany, Kaarst
Tel: +49 (0)2131 4016 0
parker.germany@parker.com

DK – Denmark, Ballerup
Tel: +45 43 56 04 00
parker.denmark@parker.com

ES – Spain, Madrid
Tel: +34 902 33 00 01
parker.spain@parker.com

FI – Finland, Vantaa
Tel: +358 (0)20 753 2500
parker.finland@parker.com

FR – France, Contamine s/Arve
Tel: +33 (0)4 50 25 80 25
parker.france@parker.com

GR – Greece, Athens
Tel: +30 210 933 6450
parker.greece@parker.com

HK – Hong Kong
Tel: +852 2428 8008

HU – Hungary, Budapest
Tel: +36 1 220 4155
parker.hungary@parker.com

IE – Ireland, Dublin
Tel: +353 (0)1 466 6370
parker.ireland@parker.com

IN – India, Mumbai
Tel: +91 22 6513 7081-85

IT – Italy, Corsico (MI)
Tel: +39 02 45 19 21
parker.italy@parker.com

JP – Japan, Fujisawa
Tel: +(81) 4 6635 3050

KR – South Korea, Seoul
Tel: +82 2 559 0400

KZ – Kazakhstan, Almaty
Tel: +7 7272 505 800
parker.easteurope@parker.com

LV – Latvia, Riga
Tel: +371 6 745 2601
parker.latvia@parker.com

MX – Mexico, Apodaca
Tel: +52 81 8156 6000

MY – Malaysia, Subang Jaya
Tel: +60 3 5638 1476

NL – The Netherlands, Oldenzaal
Tel: +31 (0)541 585 000
parker.nl@parker.com

NO – Norway, Ski
Tel: +47 64 91 10 00
parker.norway@parker.com

NZ – New Zealand, Mt Wellington
Tel: +64 9 574 1744

PL – Poland, Warsaw
Tel: +48 (0)22 573 24 00
parker.poland@parker.com

PT – Portugal, Leca da Palmeira
Tel: +351 22 999 7360
parker.portugal@parker.com

RO – Romania, Bucharest
Tel: +40 21 252 1382
parker.romania@parker.com

RU – Russia, Moscow
Tel: +7 495 645-2156
parker.russia@parker.com

SE – Sweden, Spånga
Tel: +46 (0)8 59 79 50 00
parker.sweden@parker.com

SG – Singapore
Tel: +65 6887 6300

SK – Slovakia, Banská Bystrica
Tel: +421 484 162 252
parker.slovakia@parker.com

SL – Slovenia, Novo Mesto
Tel: +386 7 337 6650
parker.slovenia@parker.com

TH – Thailand, Bangkok
Tel: +662 717 8140

TR – Turkey, Istanbul
Tel: +90 216 4997081
parker.turkey@parker.com

TW – Taiwan, Taipei
Tel: +886 2 2298 8987

UA – Ukraine, Kiev
Tel +380 44 494 2731
parker.ukraine@parker.com

UK – United Kingdom, Warwick
Tel: +44 (0)1926 317 878
parker.uk@parker.com

US – USA, Cleveland (industrial)
Tel: +1 216 896 3000

US – USA, Lincolnshire (mobile)
Tel: +1 847 821 1500

VE – Venezuela, Caracas
Tel: +58 212 238 5422

ZA – South Africa, Kempton Park
Tel: +27 (0)11 961 0700
parker.southafrica@parker.com

European Product Information Centre
Free phone: 00 800 27 27 5374
(from AT, BE, CH, CZ, DE, EE, ES, FI, FR, IE, IT, PT, SE, SK, UK)



Parker Hannifin Ltd.
Tachbrook Park Drive
Tachbrook Park, Warwick CV34 6TU
United Kingdom
Tel.: +44 (0) 1926 317 878
Fax: +44 (0) 1926 317 855
www.parker.com