



The P70 Series

Valve	Pump flow l/min	Pressure bar	Operation			
			Manual	Pneumatic	Hydraulic	Electro-hydraulic
P70CF	70	350	•	•	•	•
P70CP	90	350	•	•	•	•
P70LS	90	350			•	•

Common features – P70 series:

- Main pressure relief valve
- Port relief valves with anti-cavitation function
- Anti-cavitation valves
- Application adapted spools
- Pressure compensated spools
- Load hold check valve
- For single or multi-pump operation

Options vary for different valves



Parker Hannifin AB
 SE-501 78 Borås
 Tel.: +46 (0)33 700 52 00
 Fax: +46 (0)33 12 11 43
www.parker.com/euro_mcd

Bulletin HY17-8510-B1/UK
 3 M 05/06 S&S

© Copyright 2006
 Parker Hannifin Corporation
 All rights reserved

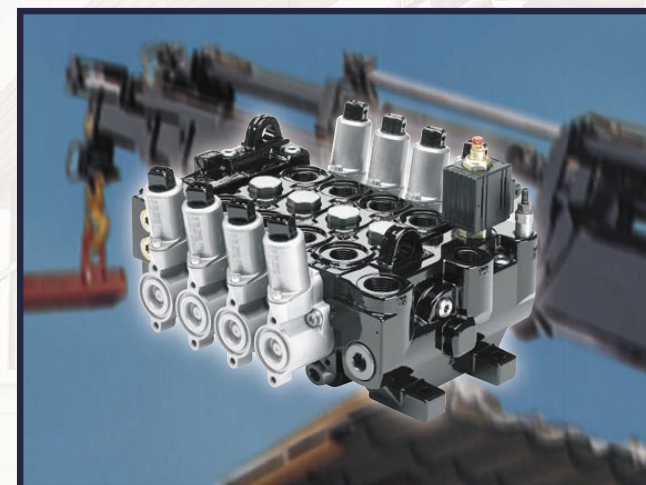

Smart performance

New efficiency for sequential applications

Modular Load Sensing Valves
 Series P70LS



The ultimate cost/performance compromise!

Open Centre technology taken to the limits!

Often when designing mobile hydraulic systems, cost considerations override desired performance, functionality and ergonomics. A high-tech load sensing system would be better in many ways, but the budget just won't stretch that far.

That is when Parker's new P70LS valve comes to the rescue. Based on a proven, economical, open centre thoroughbred technology, it enables many of the advantages of a load sensing system at a fraction of the cost.

Load sensing advantages on a budget

Without separate compensator, the P70LS achieves simultaneous function operation capabilities through our extensive spool design know-how for pilot operated valves. The P70 in its load sensing version is a top-of-the-line complement to existing open centre based machines on the market.

- **Higher productivity**
- **Load-sensing at a fraction of the cost**
- **Based on proven open centre technology**
- **Reduces fuel costs significantly**
- **Better manoeuvring precision**
- **Easy to install**
- **Modular design – expandable and upgradeable**
- **Perfect for sequential applications**
- **A global product with global back-up**
- **Simplified circuit lay-out**

Lower running costs, longer service life

The unique P70LS solution with its built-in, intelligent load-sensing abilities will give you precise control, quick reactions and a higher overall system efficiency, resulting in lower noise and lower heat losses, and ultimately considerably lower fuel consumption and an extended service life. All this has been made possible through an ingenious adaptation of our existing mass market valve technology, reducing your time-to-market without compromising performance.

Take the first step today!

The new P70LS can also be a cost-reducing option to fully load sensing valves for less demanding functions in more complex systems. The P70LS technology is an ideal first step into the world of new functionality offered by Parker's advanced load sensing technologies.

SAVE UP TO
60%
ON FUEL

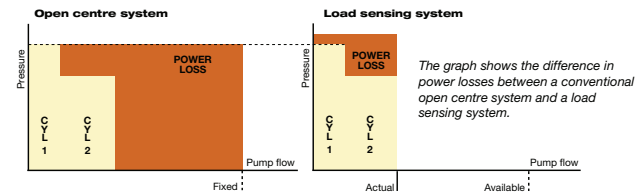
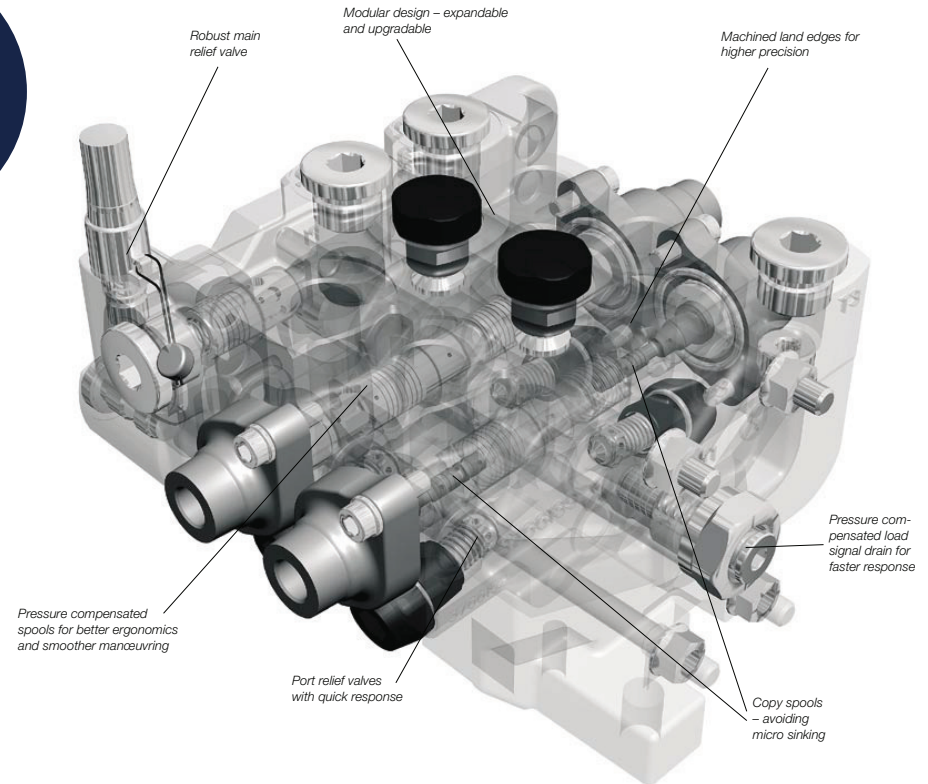

TYPICAL APPLICATIONS: REFUSE VEHICLES • SKIP LOADERS • AGRICULTURAL MACHINES • MEDIUM DUTY WHEEL LOADERS • PISTE MACHINES • FORK LIFTS • FORESTRY MACHINES • ETC.