



Remote Control VP04

*Pneumatic Proportional
Remote Control Valve*

*Catalogue HY17-8356/UK
October, 2006*



Catalogue layout

This catalogue has been designed to give a brief overview of the VP04, and to make it easy for you to study and choose from the different options available, so that we may customize your remote-control valve in accordance with your wishes. In addition to general information and basic technical data, the brochure therefore contains descriptions of the options available for the valve.

Each function area is given as a subheading, e.g. **Connections**, followed by a brief description. This is followed by a series of coded options, e.g. **M, S, P, T, R**, together with a brief description of what each code represents.

How to order your valve

The next step is to complete our so-called Customer Specification Form to specify the options and characteristics you wish to be incorporated into your remote-control valve. When all the control-pressure ports are equal you can specify the valve with the order code at page 5. To specify your valve, simply choose the options you require and enter the corresponding code into the appropriate box in the Customer Specification Form.

Should you require assistance completing the Customer Specification Form or the order code, please do not hesitate to contact your nearest Parker Hannifin representative, who will

either help personally or refer you to the appropriate product specialist.

The information in your Customer Specification Form is then entered into our computerized valve specification program, which initiates the assembly process and generates a unique product ID number that is subsequently stamped into the data plate on your valve, or if you have completed an order code this will be stamped into the plate. Your valve specifications remain on our database to facilitate subsequent re-ordering or servicing of your valve.

Early consultation with Parker Hannifin saves time and money

Our experienced engineers have in-depth knowledge of the different types of hydraulic system and the ways in which they work. They are at your disposal to offer qualified advice on the best system for the desired combination of functions, control

characteristics and economic demands. By consulting Parker early in the project planning stage, you are assured of a comprehensive hydraulic system that gives your machine the best possible operating and control characteristics.

Conversion factors

1 kg	= 2.2046 lb
1 N	= 0.22481 lbf
1 bar	= 14.504 psi
1 l	= 0.21997 UK gallon
1 l	= 0.26417 US gallon
1 cm ³	= 0.061024 in ³
1 m	= 3.2808 feet
1 mm	= 0.03937 in
9/5 °C + 32	= °F

List of contents	Page
Catalogue Information	2
Conversion factors	2
General Information	4
Order code	5
Technical Data	6
Electrical data	7
Breaking capacity	7
Connections	7
Weight	7
Control-pressure characteristic	7
Circuit	7
Control-pressure ports	8
Connection options	8
Lever options	8
Lever detent options	8
Control-pressure options	8
Dimensional drawings	9-10

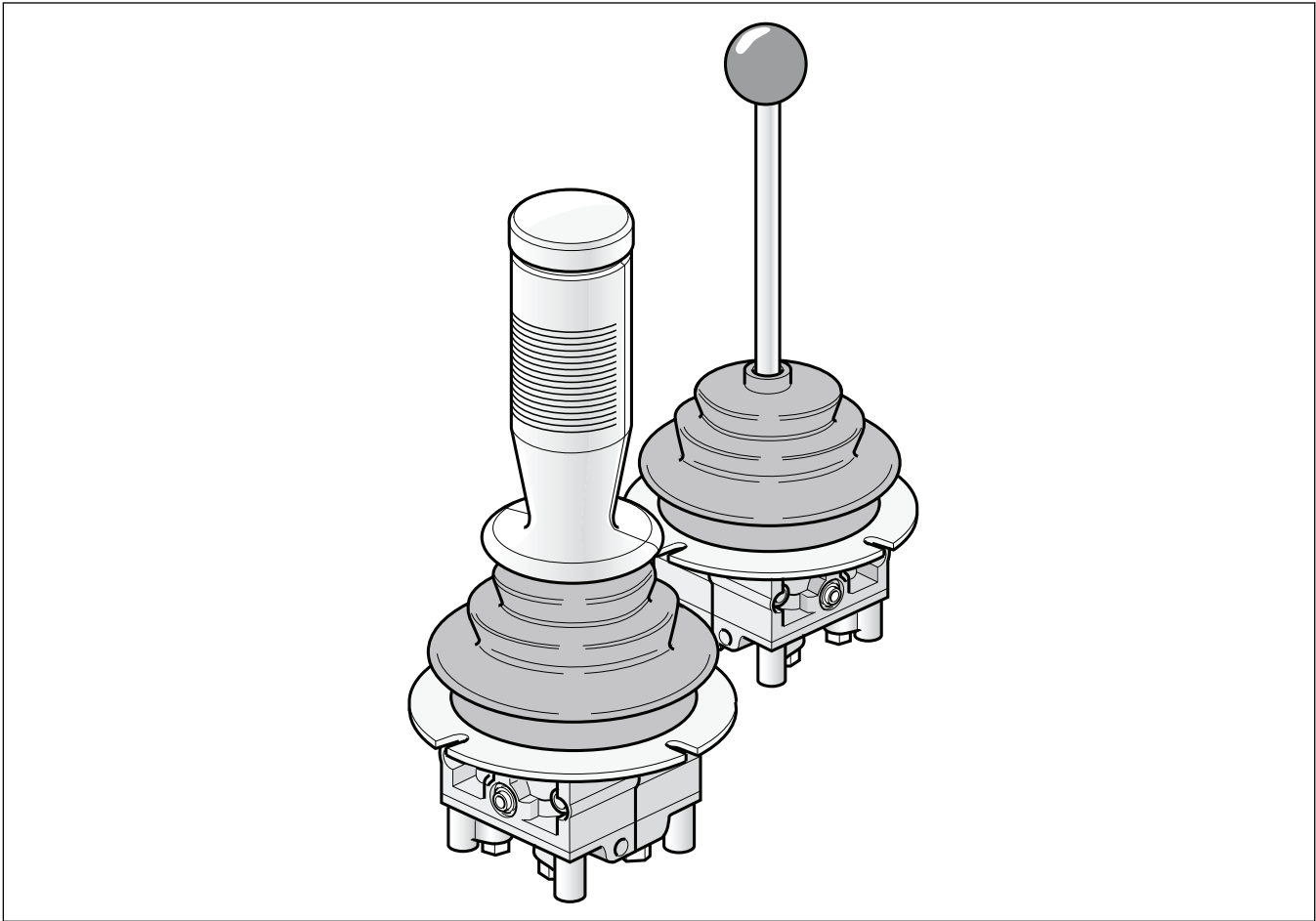

The VP04 is a stackable, pneumatic control-pressure valve intended for the proportional, pneumatic remote control of directional valves, positioning cylinders etc. It can be supplied with a coordinate lever (joystick) or different linear levers.

Freedom in machine design

Good machine design is heavily dependent on the availability of flexible components and systems that can be combined in different ways to give optimum operating and control characteristics. Parker Hannifin control systems give you the freedom to design your machines the way you want them, since they themselves are designed to enable components such as directional valves and other control devices to be located ideally on the machine. This gives advantages in production too, since it greatly facilitates the building of machine subassemblies at different sites prior to collation for final assembly.

Moreover, the wide range of Parker Hannifin pneumatic, hydraulic and electric control devices enables optimum design of the machine-control station in terms of ergonomics. (Please see separate brochures for information about our hydraulic and electric remote-control systems.)

Safety

In spite of the sophistication of the final functions it may serve, the VP04 remote control valve is of robust and simple construction. This greatly facilitates training and servicing which, together with predictable control characteristics and great dependability, does much to improve the operational safety of the machine.

Design

The valve is made up of sections, each of which contains two 3-way pressure reducing valves (one per signal port). Up to 8 sections can be stacked together to give a total of 16 signal ports. The valve can be equipped with either one linear lever per section, or with a coordinate lever (joystick) when two sections are stacked to give four signal ports.

Essential characteristics

- Low, well adapted operating forces and short lever strokes give good operator comfort.
- Small dimensions enable simple, compact installation.
- Push-in couplings enable fast, simple connection.
- Low hysteresis ensures consistent pressure output value for a given lever stroke.
- Simple design makes the valve easy to service.
- Quality materials and great precision in manufacturing, assembly and testing assure you of a quality product with low internal leakage and long service life.
- Wide range of control devices and accessories gives great flexibility in system design.
- Total compatibility with Parker Hannifin directional valves gives predictable and harmonious system characteristics.

Order code

VP04

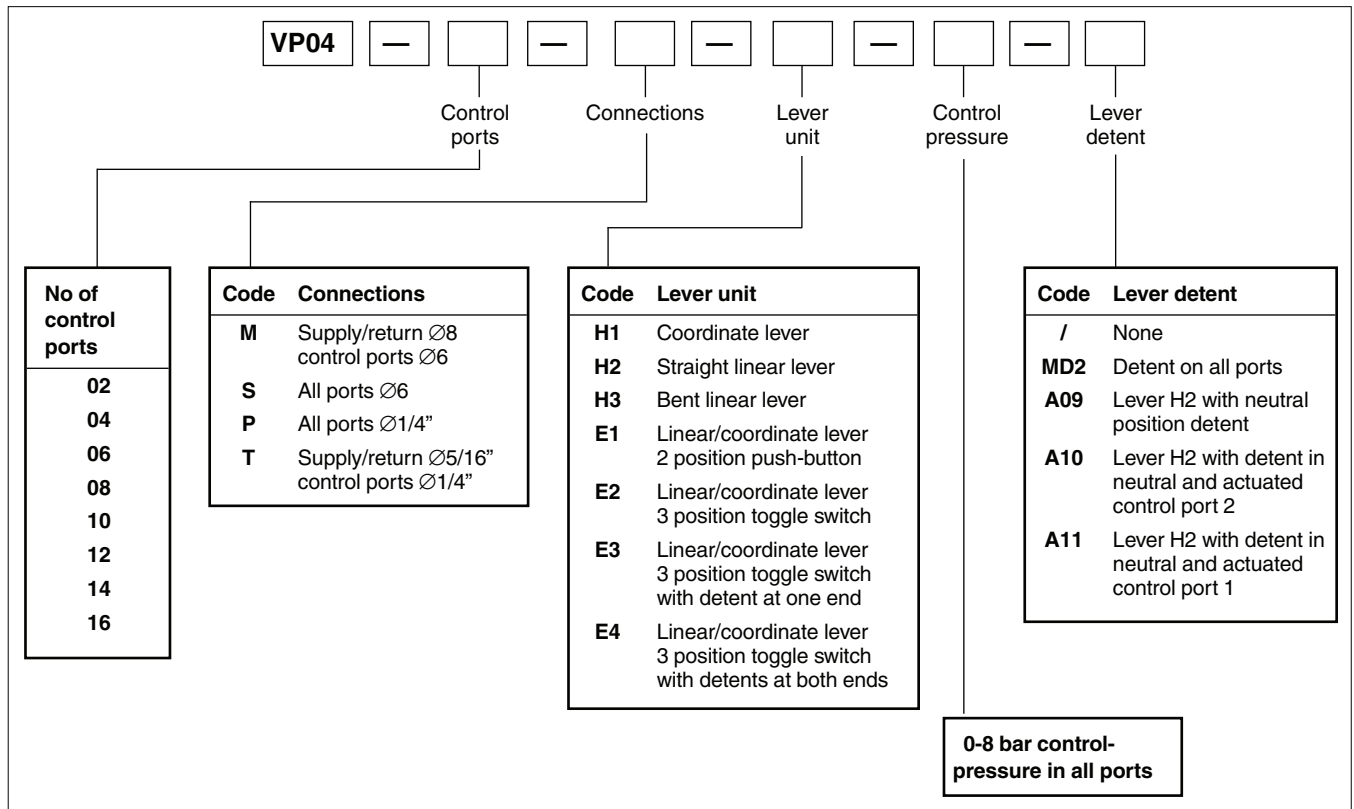

See page 7 for further description of different options.

How to order your valve

To specify your valve, simply choose the options you require and enter the corresponding code into the appropriate box in the Customer Specification Form. When all the control-pressure ports are equal you can specify the valve with the order code above.

Should you require assistance completing the Customer Specification Form or the order code, please do not hesitate to contact your nearest Parker Hannifin representative, who will either help personally or refer you to the appropriate product specialist.

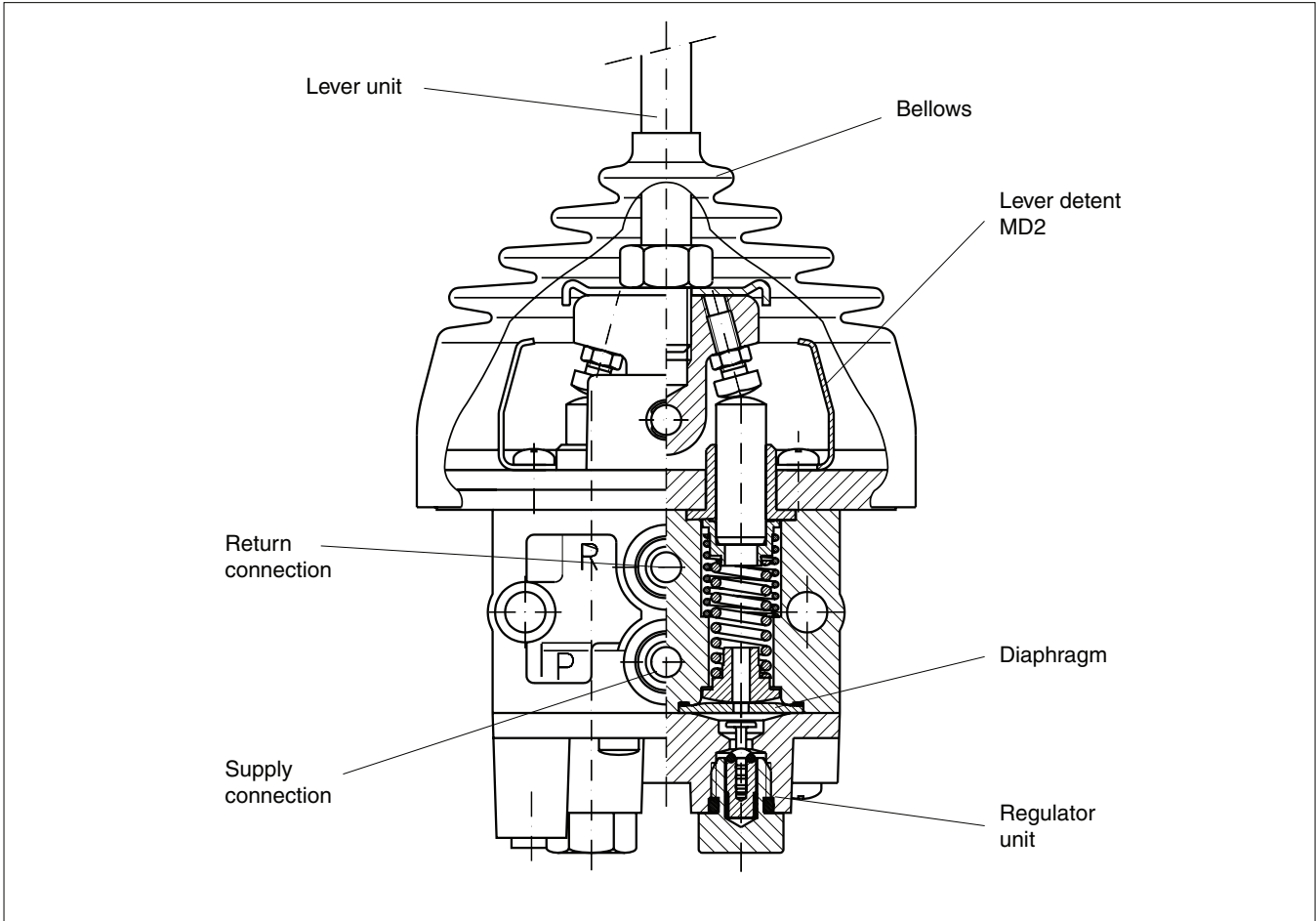

Pressure

Supply pressure (at least 2 bar higher than max. control pressure)	max. 10 bar (145 psi)
Control pressure	max. 8 bar (116 psi)

Lever forces

Normal force for linear lever fully actuated	3.1 Nm (2.29 lbf-ft)
Normal force for coordinate lever one function fully actuated	3.9 Nm (2.88 lbf-ft)
two functions fully actuated	5.5 Nm (4.06 lbf-ft)

Volume rate of flow

Control flow at $\Delta p = 6$ bar (87 psi)	7 NI/s (14.8 cfm free flow)
---	-----------------------------

Hysteresis

Hysteresis	max. 1 bar (14.5 psi)
------------	-----------------------

Temperature

Min. ambient temperature	-30 °C (86 °F) (assuming dry air or use of agent to reduce freezing-point).
Max. ambient temperature	+70 °C (158 °F)

Air quality

The air quality determines the service life of the valve.
 See ISO 8573.

Filter

Filtration	max. 20 μ m or better
------------	---------------------------



Warning

If the filtration demands are not met, the valve poppet can jam in the open position, with the result that the valve remains actuated. It is not possible to force back a jammed poppet mechanically.

Electrical data

Concerns switch in E-type levers.
Data given below is what is needed to obtain maximum service life. The values can be exceeded with retained function, but will result in a reduction in service life. In the event of inductive loading, a protective diode must be fitted.

Breaking capacity

DC, resistive loading	2A/24V
DC or AC, inductive loading	1A/24V

Connections

All connections are equipped with push-in connectors and are available for different pipe dimensions.

Signal ports are available with connections for Ø6 mm or Ø1/4" pipe. Supply and return ports are available with connections for Ø6 mm, Ø8 mm, Ø1/4" or Ø5/16" pipe.

Weight

The weight of the unit varies somewhat, depending on configuration.

Linear lever approx.	0.8 kg/section (1.76 lb)
Coordinate lever	approx. 1.7 kg (3.75 lb)

Control-pressure characteristic

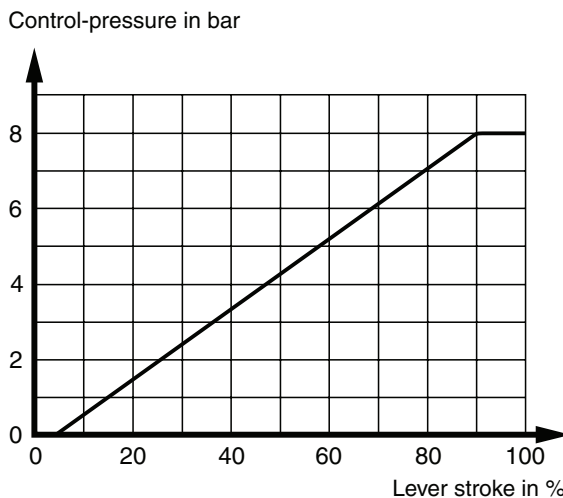
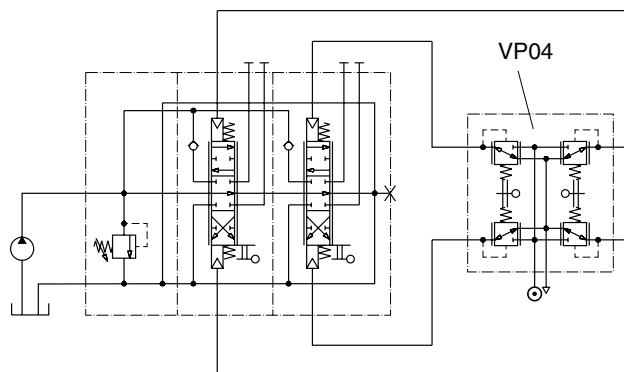
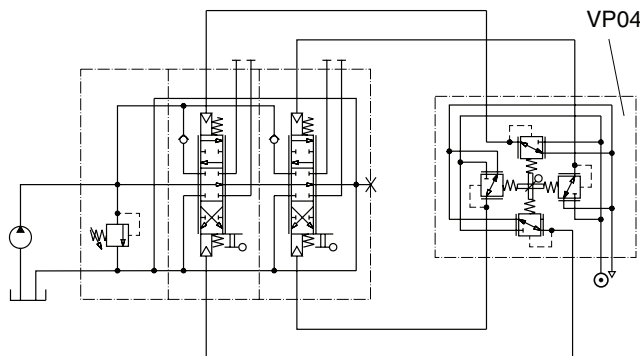

Diagram showing control-pressure characteristic of the VP04-valve. Valid for 8 - 10 bar supply pressure. If lower the curve will level out at obtained supply pressure.

Circuit



Circuit diagram showing two-section VP04 with two linear levers controlling one hydraulic directional valve with two spool sections.



Circuit diagram showing two-section VP04 with one coordinate lever (joystick) controlling one hydraulic directional valve with two spool sections.

Every valve is customized. The following options are used to configure a valve.

Control-pressure ports

2-16 Each valve section contains two control-pressure ports. Two valve sections are needed for coordinate levers (joysticks), since they require 4 control-pressure ports.

Connection options

- M** For Ø8 mm pipe in supply and return ports, and Ø6 mm pipe in the control-pressure ports.
- S** For Ø6 mm pipe in all ports.
- P** For Ø1/4" pipe in all ports.
- T** For Ø5/16" pipe in supply and return ports, and Ø1/4" pipe in the control-pressure ports.

Lever options

Lever units are available in several different versions. For coordinate movements (4 control-pressure ports), the H1, E1, E2, E3 and E4 units can be used.

For linear movements (2 control-pressure ports), the H2, H3, E1, E2, E3 and E4 units can be used. Owing to the width of the lever unit, only E-levers can be used for valves containing two control-pressure ports, unless a special spacer block is fitted between the sections. E-levers contain a switch that can be used for different external functions.

- H1** Coordinate lever (joystick) with ball.
- H2** Straight linear lever with ball.
- H3** Bent linear lever with ball.
- E1** Linear or coordinate lever (joystick) with 2-position push-button switch.
- E2** Linear or coordinate lever (joystick) with 3-position, spring-centred toggle switch.
- E3** Linear or coordinate lever (joystick) with 3-position toggle switch with detent at one end position.
- E4** Linear or coordinate lever (joystick) with 3-position toggle switch with detents at both end positions.

Lever detent options

- MD2** Detent for linear levers that locks the lever in the fully actuated position. The lever is moved out of the detented position by pulling it to release the detent.
- A09** Detent for H2 lever that locks the lever in the neutral position. To move the lever out of neutral, the detent must be disengaged by lifting with the fingers.
- A10** Same as A09, but locks the lever in the neutral position and in one fully actuated position (port 2).
- A11** Same as A09, but locks the lever in the neutral position and in one fully actuated position (port 1).

Control-pressure options

The control-pressure curve is proportional to the lever stroke. For maximum signal pressure to be obtained, the supply pressure must be at least 2 bar higher than the maximum control pressure.

- 8** Max. actuation gives a 8 bar control-pressure signal.
- A24** Max. actuation gives a 7 bar control-pressure signal.

E1

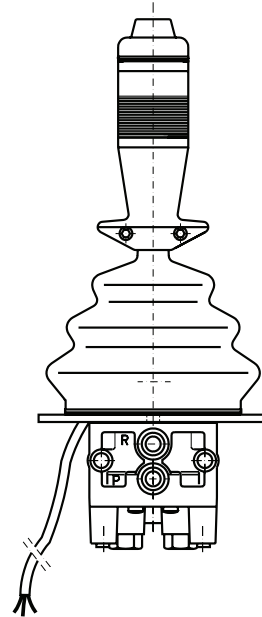

Switch symbol

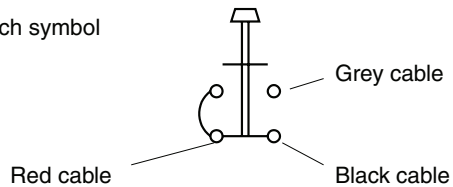

E2, E3, E4

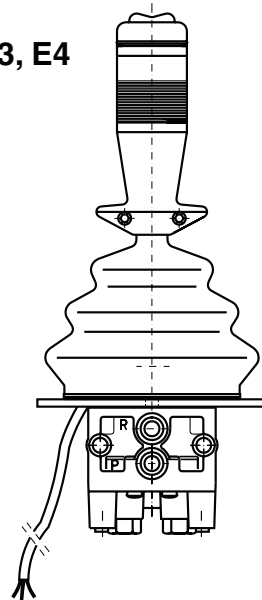

Switch symbol

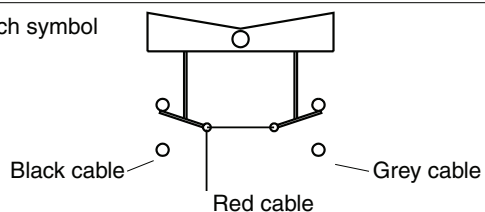

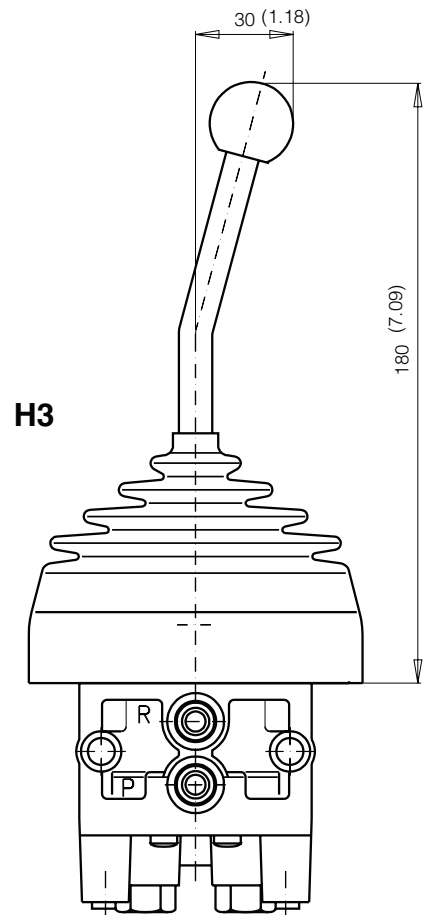
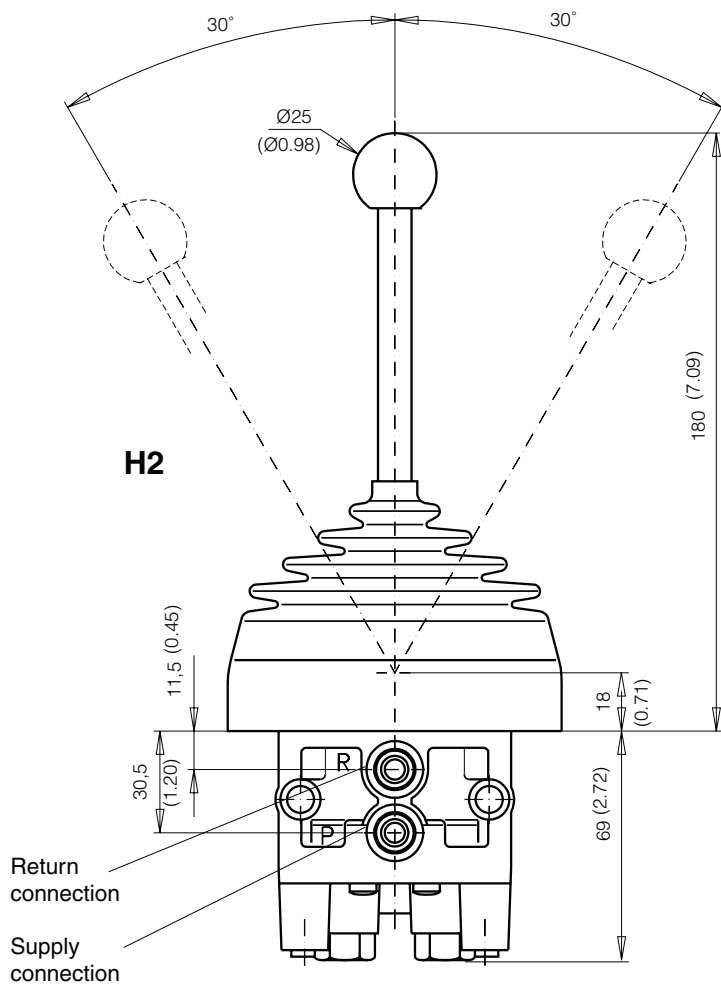
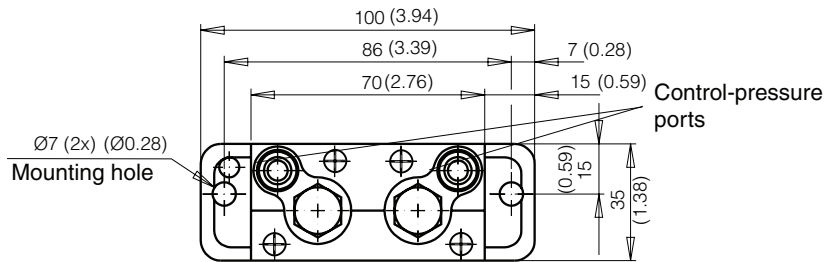

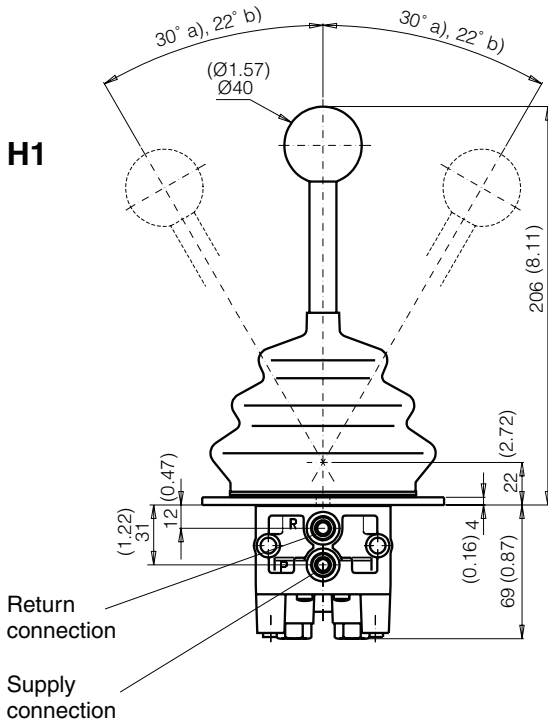
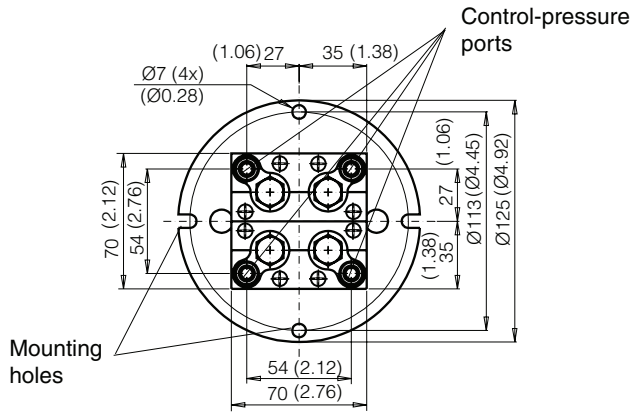

a) Applies to max. actuation of two function.
 b) Applies to max. actuation of one functions.

E1

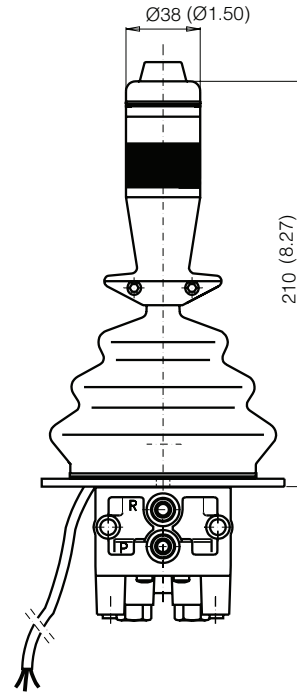

E2, E3, E4

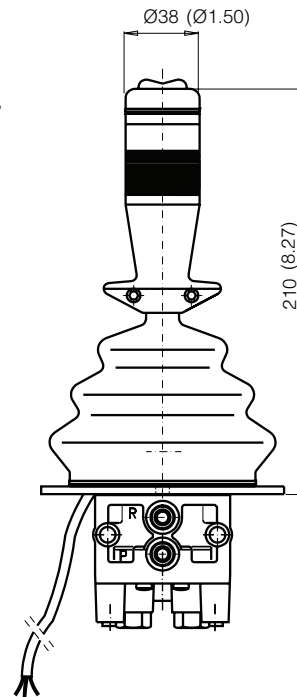

**WARNING**

FAILURE OR IMPROPER SELECTION OR IMPROPER USE OF THE PRODUCTS AND/OR SYSTEMS DESCRIBED HEREIN OR RELATED ITEMS CAN CAUSE DEATH, PERSONAL INJURY AND PROPERTY DAMAGE.

This document and other information from Parker Hannifin Corporation, its subsidiaries and authorized distributors provide product and/or system options for further investigation by users having technical expertise. It is important that you analyze all aspects of your application, including consequences of any failure, and review the information concerning the product or system in the current product catalogue. Due to the variety of operating conditions and applications for these products or systems, the user, through its own analysis and testing, is solely responsible for making the final selection of the products and systems and assuring that all performance, safety and warning requirements of the application are met.

The products described herein, including without limitation, product features, specifications, designs, availability and pricing, are subject to change by Parker Hannifin Corporation and its subsidiaries at any time without notice.

Offer of Sale

Please contact your Parker representation for a detailed "Offer of Sale".

Hydraulics Group Sales Offices

Europe

Austria

Wiener Neustadt

Tel: +43 (0)2622 23501
Fax: +43 (0)2622 66212

Austria

Wiener Neustadt

(Resp for East Europe)

Tel: +43 (0)2622 23501-970
Fax: +43 (0)2622 23501-977

Belgium

Nivelles

Tel: +32 (0)67 280 900
Fax: +32 (0)67 280 999

Czech Republic

Klecany

Tel: +420 284 083 111
Fax: +420 284 083 112

Denmark

Ballerup

Tel: +45 4356 0400
Fax: +45 4373 3107

Finland

Vantaa

Tel: +358 20 753 2500
Fax: +358 20 753 2200

France

Contamine-sur-Arve

Tel: +33 (0)450 25 80 25
Fax: +33 (0)450 25 24 25

Germany

Kaarst

Tel: +49 (0)2131 4016 0
Fax: +49 (0)2131 4016 9199

Ireland

Dublin

Tel: +353 (0)1 293 9999
Fax: +353 (0)1 293 9900

Italy

Corsico (MI)

Tel: +39 02 45 19 21
Fax: +39 02 4 47 93 40

The Netherlands

Oldenzaal

Tel: +31 (0)541 585000
Fax: +31 (0)541 585459

Norway

Ski

Tel: +47 64 91 10 00
Fax: +47 64 91 10 90

Poland

Warsaw

Tel: +48 (0)22 573 24 00
Fax: +48 (0)22 573 24 03

Portugal

Leca da Palmeira

Tel: +351 22 9997 360
Fax: +351 22 9961 527

Slovakia

Ref. Czech Republic

Spain

Madrid

Tel: +34 91 675 73 00
Fax: +34 91 675 77 11

Sweden

Spånga

Tel: +46 (0)8 597 950 00
Fax: +46 (0)8 597 951 10

United Kingdom

Warwick

Tel: +44 (0)1926 317 878
Fax: +44 (0)1926 317 855

International

Australia

Castle Hill

Tel: +61 (0)2-9634 7777
Fax: +61 (0)2-9842 5111

Canada

Milton, Ontario

Tel: +1 905-693-3000
Fax: +1 905-876-0788

China

Shanghai

Tel: +86 21 5031 2525
Fax: +86 21 5834 3714

Asia Pacific Group

Hong Kong

Tel: +852 2428 8008
Fax: +852 2425 6896

India

Mumbai

Tel: +91 22 5613 7081/82-85
Fax: +91 22 2768 6841/6618

Japan

Tokyo

Tel: +(81) 3 6408 3900
Fax: +(81) 3 5449 7201

Latin America Group

Brazil

Tel: +55 51 3470 9144
Fax: +55 51 3470 9281

South Africa

Kempton Park

Tel: +27 (0)11-961 0700
Fax: +27 (0)11-392 7213

USA

Cleveland (industrial)

Tel: +1 216-896-3000
Fax: +1 216-896-4031

Lincolnshire (mobile)

Tel: +1 847-821-1500
Fax: +1 847-821-7600

Parker Hannifin is the world's premier supplier of motion and control systems and solutions, with sales and manufacturing facilities throughout the world. For product information and details of your nearest Parker sales office, visit us at www.parker.com or call free on 00800 2727 5374.



Catalogue HY17-8356/UK
PDF 10/2006

© Copyright 2006
Parker Hannifin Corporation
All rights reserved.