



Bulletin HY07-1244-T1/UK

Operating Instructions UCA Charging & Gauging Kit

Effective: 01 July 2001

For use with Piston,
Bladder & Diaphragm
Accumulators



Warning

FAILURE OR IMPROPER SELECTION OR IMPROPER USE OF THE PRODUCTS AND/OR SYSTEMS DESCRIBED HEREIN OR RELATED ITEMS CAN CAUSE DEATH, PERSONAL INJURY AND PROPERTY DAMAGE.

This document and other information from Parker Hannifin Corporation, its subsidiaries and authorized distributors provide product and/or system options for further investigation by users having technical expertise. It is important that all aspects of the application are analysed and the information concerning the product or system in the current product catalogue is reviewed. Due to the variety of operating conditions and applications for these products or systems, the user, through its own analysis and testing, is solely responsible for making the final selection of the products and systems and assuring that all performance, safety and warning requirements of the application are met.

The products described herein, including without limitation, product features, specifications, designs, availability and pricing, are subject to change by Parker Hannifin Corporation and its subsidiaries at any time without notice.

Description

The UCA universal charging & gauging kit is required to check the precharge pressure of an accumulator and to fill and vent the nitrogen. It is suitable for all Parker piston and bladder accumulators, and other commercially available accumulators with M28 x 1.5, 7/8-14 UNF, 5/8-18 UNF or Q.305-32 UNS (8V1-Vg 8) gas valves, operating up to a maximum working pressure of 340bar.

The UCA assembly is screwed onto the accumulator's gas valve and connected to the nitrogen source with the hose supplied. If the precharge pressure is only to be checked or reduced, the connection hose is not required.

The standard charging and gauging kit is supplied in a case containing:

- a 'UCA' universal charging & gauging kit with M28 x 1.5 gas port connection
- two pressure gauges, 0-25 bar and 0-250 bar *
- three adapters for connection to the accumulator gas valve (7/8-14 UNF; 5/8-18 UNF; Q.305-32 UNS)
- a 2.5m long hose, for connection to a nitrogen source
- a 6mm A/F hexagon wrench
- a set of spare seals

* where a different pressure range is required, a commercially-available pressure gauge may be used.

Safety

Charging must be carried out by qualified personnel.

Before taking any readings or pressurizing with nitrogen, the accumulator **must** be isolated from the hydraulic system and the fluid side discharged in order to depressurize it. Use only nitrogen (N₂) to pressurize the accumulator.

Danger of Explosion – Never Charge with Oxygen

The types of nitrogen permitted are: type S (99.8% pure); type R (99.99% pure); type U (99.993% pure).

If the pressure of the gas contained in the nitrogen bottle is greater than the maximum permissible operating pressure of the accumulator, a pressure regulator **must** be fitted to the nitrogen bottle.

Parker recommends that the precharge should be checked during the first week following commissioning of the system. Thereafter, it should be checked after three months and then at intervals of 12 months or less, as considered appropriate by the system builder.

The Effect of Temperature on Precharge Pressure

In order to compensate for the difference in pressure at ambient and operating temperatures, it is recommended that the precharge pressure p₀ should be adjusted to reflect the operating temperature of the system, using the correction factor equations and table on page 7.

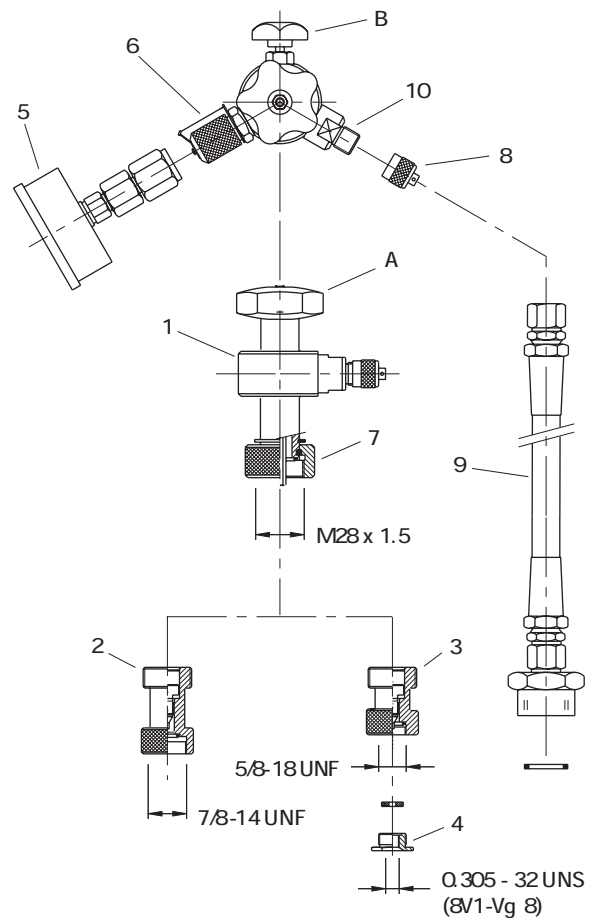

Figure 1 Universal Charging and Gauging Kit assembly

Controls

- A Inflation valve
- B Bleed valve

Key

- 1 UCA
- 2 Adapter (long)
- 3 Adapter (short)
- 4 Adapter (insert)
- 5 Pressure gauge
- 6 Knurled protective cap – gauge port
- 7 Knurled collar – gas port
- 8 Knurled protective cap – filling port
- 9 Filling hose (G 1/4 fitting, 60° cone)
- 10 Filling port valve

To Check and Adjust the Precharge Pressure

Warning – Stabilization

The process of charging or discharging an accumulator with nitrogen causes a temperature change which is transmitted to the surrounding air as the temperature of the accumulator stabilizes. To allow for the effects of temperature transfer, the accumulator should be allowed to stand for a minimum of 15 minutes before a final reading of the precharge pressure is taken.

Bladder or Piston Accumulators with Schrader-type Valve Figures 1, 2a & 2b

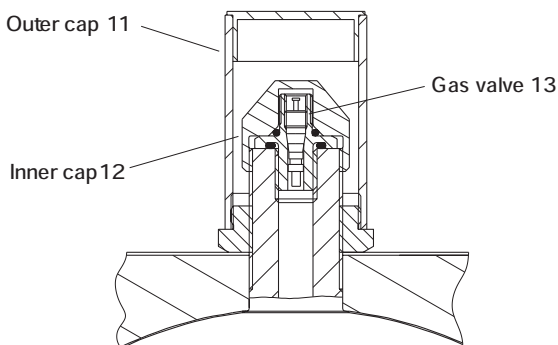

Figure 2a Bladder accumulator with Schrader-type gas valve

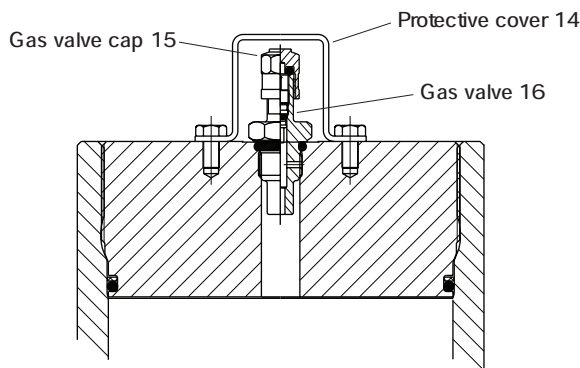

Figure 2b Piston accumulator with Schrader-type gas valve

- 1 Unscrew the caps (11 and 12) from a bladder accumulator or the protective cover and cap (14 and 15) from a piston accumulator, to gain access to the gas valve (13 or 16).
- 2 Select the appropriate pressure gauge (5) for the pressure to be checked, remove the protective cap (6) and attach the gauge to the UCA (1).
- 3 Make sure that the bleed valve (B) is fully closed and that the inflation valve (A) is in the fully **raised** position by turning the handwheel in an anti-clockwise direction.
- 4 **Bladder accumulators:** Ensure that the o-ring is correctly positioned in the base of the long adapter (2), screw the adapter on to the gas valve (13) and hand tighten.
Piston accumulators: Assemble the short adapter and adapter insert (3 and 4), screw onto the gas valve (16) and hand tighten.
- 5 Screw the UCA onto the adapter. Position the assembly to permit easy reading of the gauge, then hand tighten the knurled collar (7).

- 6 Open the inflation valve (A) by screwing the handwheel **clockwise** until the inflation pressure registers on the gauge.

Readings and Results

One of three conditions will apply – the precharge pressure in the accumulator will be correct, or it will be too high or too low.

Nitrogen Pressure p_o is Correct

- 1 Screw the handwheel (A) **anti-clockwise** to close the accumulator gas valve.
- 2 Slacken the bleed valve (B) to release pressure in the UCA.
- 3 Unscrew the UCA from the adapter.
- 4 Unscrew the adapter(s) from the accumulator gas valve.

Nitrogen Pressure p_o is Too High

- 1 Slacken the bleed valve (B) to vent nitrogen from the accumulator until, after stabilization, the desired pressure p_o is registered. Nitrogen vents into the air.
- 2 Tighten the bleed valve (B) once the desired filling pressure is reached.
- 3 Screw the handwheel (A) **anti-clockwise** to close the accumulator gas valve.
- 4 Slacken the bleed valve (B) to release pressure in the UCA.
- 5 Unscrew the UCA from the adapter.
- 6 Unscrew the adapter(s) from the accumulator gas valve.

Nitrogen Pressure p_o is Too Low

- 1 Close the inflation valve (A) by screwing the handwheel **anti-clockwise**.
- 2 Remove the knurled cap on the filling port (8).
- 3 Connect the end of the filling hose (9) to the filling port valve (10).
- 4 Connect the other end of the hose to the nitrogen source.
- 5 Progressively open the valve on the nitrogen source.
- 6 Screw the handwheel (A) **clockwise** to admit the pressurized gas, taking particular care if the accumulator has a small capacity or is of the low pressure type (< 40bar).
- 7 When pressure p_o is reached, close the valve on the nitrogen source. To allow for the effects of temperature transfer, the accumulator should be allowed to stand for a minimum of 15 minutes to allow the temperature to stabilize before a final reading of the precharge pressure is taken.
- 8 Screw the handwheel (A) **anti-clockwise** to close the accumulator gas valve.
- 9 Slacken the bleed valve (B) to release pressure in the UCA.
- 10 Remove the hose carefully, to release internal pressure.
- 11 Refit the knurled cap (8) to the filling port valve (10).
- 12 Unscrew the UCA from the adapter(s).
- 13 Unscrew the adapter(s) from the accumulator gas valve.

After removing the UCA and adapter(s), make sure that the accumulator gas valve (13 or 16) is sealing effectively. Refit the protective cap(s) (11, 12, 15) and cover (14), where applicable.

**Piston Accumulators with
Poppet-type Valve** Figures 1 & 3

- 1 Unscrew the protective cover (17), where fitted, and cap (18) from the accumulator gas valve (19).
- 2 Assemble the short adapter and adapter insert (3 and 4), and screw onto the accumulator gas valve.
- 3 Select the appropriate pressure gauge (5) for the pressure to be checked, remove the protective cap (6) and attach the gauge to the UCA (1). Make sure that the bleed valve (B) is fully closed. The position of inflation valve (A) can be ignored, as it does not affect this procedure.
- 4 Screw the UCA onto the adapter. Position the assembly to permit easy reading of the gauge, then hand tighten the knurled collar (7).
- 5 Open the accumulator gas valve by turning the hexagonal poppet valve adjuster nut (20) **anti-clockwise** until the inflation pressure registers on the gauge.

Note: for 360mm bore accumulators, a 19mm A/F spanner approximately 120mm long should be used to turn the valve adjuster nut (20).

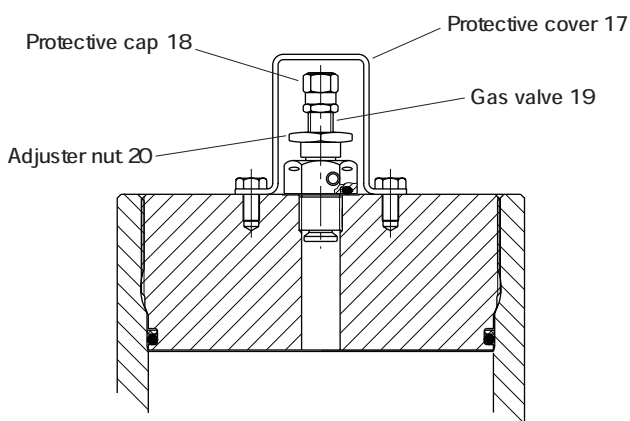

Figure 3 Poppet-type accumulator gas valve

Readings and Results

One of three conditions will apply – the precharge pressure in the accumulator will be correct, or it will be too high or too low.

Nitrogen Pressure p_o is Correct

- 1 Close the accumulator gas valve by turning the poppet valve adjuster nut (20) **clockwise**.
- 2 Slacken the bleed valve (B) to release pressure in the UCA.
- 3 Unscrew the UCA from the adapter.
- 4 Unscrew the adapter (3) and adapter insert (4) from the accumulator gas valve (19).

Nitrogen Pressure p_o is Too High

- 1 Slacken the bleed valve (B) to vent nitrogen from the accumulator until, after stabilization, the desired pressure p_o is registered. Nitrogen vents into the air.
- 2 Tighten the bleed valve (B) once the desired filling pressure is reached.
- 3 Close the accumulator gas valve by screwing the adjuster nut (20) **clockwise**.
- 4 Slacken the bleed valve (B) to release pressure in the UCA.
- 5 Unscrew the UCA from the adapter.
- 6 Unscrew the adapter (3) and adapter insert (4) from the accumulator gas valve (19).

Nitrogen Pressure p_o is Too Low

- 1 Close the accumulator gas valve by screwing the poppet valve adjuster nut (20) **clockwise**.
- 2 Remove the knurled cap on the filling port (8).
- 3 Connect the end of the filling hose (9) to the filling port valve (10).
- 4 Connect the other end of the hose to the nitrogen source.
- 5 Progressively open the valve on the nitrogen source.
- 6 Open the accumulator gas valve by screwing the adjuster nut (20) **anti-clockwise**, to admit the pressurized gas, taking particular care if the accumulator has a small capacity or is of the low pressure type (< 40bar).
- 7 When pressure p_o is reached, close the valve on the nitrogen source. To allow for the effects of temperature transfer, the accumulator should be allowed to stand for a minimum of 15 minutes to allow the temperature to stabilize before a final reading of the precharge pressure is taken.
- 8 Close the accumulator gas valve by screwing the adjuster nut (20) **clockwise**.
- 9 Slacken the bleed valve (B) to release pressure in the UCA.
- 10 Remove the hose (9) carefully, to release internal pressure.
- 11 Refit the knurled cap (8) to the filling port valve (10).
- 12 Unscrew the UCA from the adapter.
- 13 Unscrew the adapter (3) and adapter insert (4) from the accumulator gas valve (19).

After removing the UCA and adapters, make sure that the accumulator gas valve is sealing effectively. Refit the protective cap (18) and protective cover (17) to the accumulator gas valve (19).

Diaphragm Accumulators Figures 1 & 4

The following instructions apply only to diaphragm accumulators fitted with a socket-headed screw type gas valve, as illustrated in Figure 4.

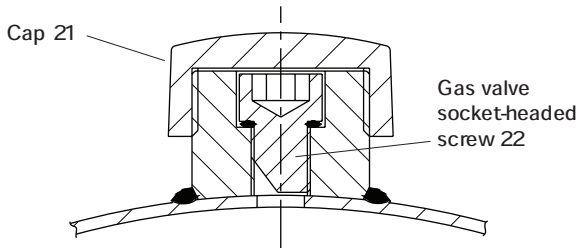

Figure 4 Diaphragm accumulator with socket-headed screw gas valve

Danger – do not attempt to loosen the gas valve screw with a hexagon wrench, as it could be ejected under extreme pressure

- 1 Select the appropriate pressure gauge (5) for the pressure to be checked, remove the protective cap (6) and attach the gauge to the UCA (1). Make sure that the bleed valve (B) is fully closed.
- 2 Unscrew the cap (21) from the accumulator gas valve. Release, **but do not loosen**, the socket-headed gas valve screw (22) using the 6mm hexagon wrench supplied.
- 3 Screw the knurled collar (7) on the base of the UCA (1) onto the accumulator gas valve. Ensure that the male hexagon in the base of the UCA engages with the female hexagon in the accumulator gas valve (22).
- 4 Open the inflation valve (A) by screwing the handwheel **anti-clockwise** until the inflation pressure registers on the gauge.

Readings and Results

One of three conditions will apply – the precharge pressure in the accumulator will be correct, or it will be too high or too low.

Nitrogen Pressure p_0 is Correct

- 1 Screw the handwheel (A) **clockwise** to close the accumulator gas valve.
- 2 Slacken the bleed valve (B) to release pressure in the UCA.
- 3 Unscrew the UCA from the accumulator gas valve.
- 4 Using the 6mm hexagon wrench supplied, ensure that the hexagon socket-headed gas valve screw (22) is firmly tightened. Refit the protective cap (21) to the accumulator gas valve.

Nitrogen Pressure p_0 is Too High

- 1 Slacken the bleed valve (B) to vent nitrogen from the accumulator until, after stabilization, the desired pressure p_0 is registered. Nitrogen vents into the air.
- 2 Tighten the bleed valve (B) once the desired filling pressure is reached.
- 3 Screw the handwheel (A) **clockwise** to close the accumulator gas valve.
- 4 Slacken the bleed valve (B) to release pressure in the UCA.
- 5 Unscrew the UCA from the accumulator gas valve.
- 6 Using the 6mm hexagon wrench supplied, ensure that the hexagon socket-headed gas valve screw (22) is firmly tightened. Refit the protective cap (21) to the accumulator gas valve.

Nitrogen Pressure p_0 is Too Low

- 1 Close the inflation valve (A) by screwing the handwheel **clockwise**.
- 2 Remove the knurled cap (8) on the filling port
- 3 Connect the end of the filling hose (9) to the filling port valve (10).
- 4 Connect the other end of the hose to the nitrogen source.
- 5 Progressively open the valve on the nitrogen source.
- 6 Screw the handwheel (A) **anti-clockwise** to admit the pressurized gas, taking particular care if the accumulator has a small capacity or is of the low pressure type (< 40bar).
- 7 When pressure p_0 is reached, close the valve on the nitrogen source. To allow for the effects of temperature transfer, the accumulator should be allowed to stand for a minimum of 15 minutes to allow the temperature to stabilize before a final reading of the precharge pressure is taken.
- 8 Screw the handwheel (A) **clockwise** to close the accumulator gas valve.
- 9 Slacken the bleed valve (B) to release pressure in the UCA.
- 10 Remove the hose carefully, to release internal pressure.
- 11 Refit the knurled cap (8) to the filling port valve (10).
- 12 Unscrew the UCA from the accumulator gas valve.
- 13 Using the 6mm hexagon wrench supplied, ensure that the hexagon socket-headed gas valve screw (22) is firmly tightened. Refit the protective cap (21) to the accumulator gas valve.

Calculation of Correction Factors at Full Pressure

$$p_o(t_o) = p_o(t_2) \frac{t_o + 273}{t_2 + 273} = p_o(t_2) \times K$$

where: $p_o(t_2)$ = precharge pressure at working temperature t_2
 $p_o(t_o)$ = precharge pressure at precharge temperature t_o
K = correction factor

Table of Correction Factors

Precharge Temperature t_o °C

Operating Temperature t_2 °C	Precharge Temperature t_o °C																
	-20	-10	0	5	10	15	20	25	30	35	40	50	60	70	80	90	100
-20	1.00	1.04	1.08	1.10	1.12	1.14	1.16	1.18	1.20	1.22	1.24	1.28	1.32	1.36	1.40	1.43	1.47
-10	0.96	1.00	1.04	1.06	1.08	1.10	1.11	1.13	1.15	1.17	1.19	1.23	1.27	1.30	1.34	1.38	1.42
0	0.93	0.96	1.00	1.02	1.04	1.05	1.07	1.09	1.11	1.13	1.15	1.18	1.22	1.26	1.29	1.33	1.37
10	0.89	0.93	0.96	0.98	1.00	1.02	1.04	1.05	1.07	1.09	1.11	1.14	1.18	1.21	1.25	1.28	1.32
20	0.86	0.90	0.93	0.95	0.97	0.98	1.00	1.02	1.03	1.05	1.07	1.10	1.14	1.17	1.20	1.24	1.27
30	0.84	0.87	0.90	0.92	0.93	0.95	0.97	0.98	1.00	1.02	1.03	1.07	1.10	1.13	1.16	1.20	1.23
40	0.81	0.84	0.87	0.89	0.90	0.92	0.94	0.95	0.97	0.98	1.00	1.03	1.06	1.10	1.13	1.16	1.19
50	0.78	0.81	0.85	0.86	0.88	0.89	0.91	0.92	0.94	0.95	0.97	1.00	1.03	1.06	1.09	1.12	1.15
60	0.76	0.79	0.82	0.83	0.85	0.86	0.88	0.89	0.91	0.92	0.94	0.97	1.00	1.03	1.06	1.09	1.12
70	0.74	0.77	0.80	0.81	0.83	0.84	0.85	0.87	0.88	0.90	0.91	0.94	0.97	1.00	1.03	1.06	1.09
80	0.72	0.75	0.77	0.79	0.80	0.82	0.83	0.84	0.86	0.87	0.89	0.92	0.94	0.97	1.00	1.03	1.06
90	0.70	0.72	0.75	0.77	0.78	0.79	0.81	0.82	0.83	0.85	0.86	0.89	0.92	0.94	0.97	1.00	1.03
100	0.68	0.71	0.73	0.75	0.76	0.77	0.79	0.80	0.81	0.83	0.84	0.87	0.89	0.92	0.95	0.97	1.00
110	0.66	0.69	0.71	0.73	0.74	0.75	0.77	0.78	0.79	0.80	0.82	0.84	0.87	0.90	0.92	0.95	0.97
120	0.64	0.67	0.69	0.71	0.72	0.73	0.75	0.76	0.77	0.78	0.80	0.82	0.85	0.87	0.90	0.92	0.95

Example

Satisfactory system operation requires a precharge pressure of 100bar. The operating temperature t_2 is 50°C and the temperature at precharging t_o is 20°C. From the table, a correction factor of 0.91 should be applied, giving a precharge pressure at 20°C of 91bar.

Warning – Stabilization

The process of filling or discharging an accumulator with nitrogen causes a temperature change which is transmitted to the surrounding air as the temperature of the accumulator stabilizes. To allow for the effects of temperature transfer, the accumulator should be allowed to stand for a minimum of 15 minutes to allow the temperature to stabilize before a final reading of the precharge pressure is taken.

Gas Bottle Fittings and Part Numbers

To meet the requirements of different markets, Parker's UCA Charging and Gauging Kits are supplied with an adapter to suit the appropriate gas bottle fitting.

Country	Gas Bottle Fitting	Part No.
UK	5/8BSP (male)	UCA 02
France	W 21.7x 1/4" (female)	UCA 04
Germany	W 24.32x 1/4" (female)	UCA 01
Italy	W 21.7x 1/4" (male)	UCA 05
US	0.960x 1/4" (male)	UCA 03

Technical Specification

Maximum pressure 340bar
Accumulator connection 7/8-14 UNF, 5/8-18 UNF, O 305-32 UNS, M28x 1.5
UCA – nitrogen bottle hose 2.5m long approx.
Nitrogen bottle connection 5/8" BSP with o-ring seal (UK: part no. UCA 02)
Pressure gauges Two 63mm dia. glycerine bath type, 0-25 and 0-250bar ±1.6%

Cylinder Division Sales Offices

Austria – Marchtrenk

Parker Hannifin GmbH
Tel: (7242) 56921
Fax: (7242) 5692120

Belgium – Brussels

Parker Hannifin SA NV
Tel: 67 280 900
Fax: 67 280 999

Czech Republic – Prague

Parker Hannifin Corporation
Tel: (02) 830 85 221
Fax: (02) 830 85 360

Denmark – Ishøj

Parker Hannifin Danmark A/S
Tel: 43 56 04 00
Fax: 43 73 31 07

Finland – Vantaa

Parker Hannifin Oy
Tel: 9 476 731
Fax: 9 476 73200

France – Contamine-sur-Arve

Parker Hannifin SA
Tel: 4 50 25.80.25
Fax: 4 50 03.67.37

Germany – Cologne

Parker Hannifin GmbH
Tel: (221) 71720
Fax: (221) 7172219

Hungary – Budapest

Parker Hannifin Corp.
Tel + Fax: 1 252 2539

Italy – Arsago-Seprio

Parker Hannifin S.p.A.
Tel: (0331) 765611
Fax: (0331) 765612

Netherlands – Oldenzaal

Parker Hannifin B.V.
Tel: (0541) 585000
Fax: (0541) 585459

Norway – Langhus

Parker Hannifin A/S
Tel: 64 91 10 00
Fax: 64 91 10 90

Poland – Warsaw

Parker Hannifin Corp.
Tel: (22) 863 49 42
Fax: (22) 863 49 44

Portugal – Leca da Palmeira

Parker Hannifin Portugal Lda.
Tel: (22) 999 7360
Fax: (22) 996 1527

Slovakia

Ref. Czech Republic

Spain – Madrid

Parker Hannifin Espana S.A.
Tel: (91) 675 73 00
Fax: (91) 675 77 11

Sweden – Spånga

Parker Hannifin AB.
Tel: 08 5979 50 00
Fax: 08 5979 51 20

Switzerland – Romanshorn

Hydrel A.G. Romanshorn
Tel: (714) 66 66 66
Fax: (714) 66 63 33

Turkey – Istanbul

Hidroser Hidrolik - Pnömatik
Tel: (212) 886 72 70
Fax: (212) 886 69 35

United Kingdom – Watford

Parker Hannifin Plc
Tel: (01923) 492000
Fax: (01923) 248557

Need a Parker part?

Call Parker's European Product Information Centre
on 00800 27 27 5374

Visit us at www.parker.com

